



# INSTALLATION & OWNER'S MANUAL

## ROOFTOP PACKAGE

Thank you very much for purchasing our air conditioner,  
Before using your air conditioner, please read this manual carefully and keep it for future reference.

## General Description

As the name Rooftop signifies, this unit is generally installed on the top of the roof. Also the Single Package signifies that both condenser and evaporator are enclosed in a single body (same as window type). In fact, The unit can be ideal for either rooftop or on-the-ground installation. The unit is provided with excellent performances that can be operated up to 43°C of maximum ambient temperature.

The unit is used along with ducts and has flexible air flow as per installation conditions.

This unit is ideal for Single story and Double story houses as they offer high static. With its easy installation and simple controlling system, this product is suitable for Factories, Shopping malls, Multiplex, Hotels etc.

At present, the unit capacity range goes from 3 to 5 tons.



A lot of information regarding the design & installation of this system is provided in this publication. Please utilize all the information for conducting your business efficiently, and make sure the specification, dimension or other technical data are same as provided in engineering data book before you start the project.

We look forward to your continuing support.

# Table of contents

| CONTENT                    | PAGE |
|----------------------------|------|
| ACCESSORIES-----           | 1    |
| GENERAL INFORMATION-----   | 1    |
| DIMENSIONAL DATA-----      | 2    |
| INSTALLATION-----          | 3    |
| ELECTRICAL WIRING-----     | 4    |
| OPERATING CONDITIONS ----- | 7    |
| PHYSICAL DATA-----         | 8    |
| WIND PRESSURE DATA-----    | 9    |
| PERFORMANCE DATA-----      | 10   |
| START - UP-----            | 13   |
| SYSTEM OPERATION -----     | 13   |
| MAINTENANCE-----           | 14   |

## 1. ACCESSORIES

| NAME OF ACCESSORIES | Q'ty | Qutime  |
|---------------------|------|---|
| MANUAL              | 1    | —   |
| DRAIN OUTLET        | 1    |  |
| SNAP RING           | 1    |    |
| DRAIN PIPE          | 1    |   |

## 2. GENERAL INFORMATION



### INSPECTION

- Read this entire manual before beginning installation procedures.
- Check for damage after the unit is unloaded. Report promptly, to the carrier, any damage found to the unit. Do not drop the unit.
- Check the unit's nameplate to determine if the unit is correct or the intended application. The power supply must be adequate for both the unit and all accessories.



### CAUTION

- Bodily injury can result from high voltage electrical components, fast moving fans. For protection from these inherent hazards during installation and servicing, the electrical supply must be disconnected.
- If operating checks must be performed with the unit operating, It is the technicians responsibility to recognize these hazards and proceed safely.

Read this manual carefully before attempting to install, operate, or perform maintenance on this unit. Installation and maintenance should be performed by qualified service technicians only.

Reconnect all grounding devices. All parts of this product capable of conducting electrical current are grounded. If grounding wires, screws, straps, clips nuts or washers used to complete a path to ground are removed for service, they must be returned to their original position and properly fastened.



### WARNING

- Indicates a potentially hazardous situation which, if not avoided, could result in death or serious injury.



### CAUTION

- Indicates a potentially hazardous situation which, if not avoided, may result in minor or moderate injury. It may also be used to alert against unsafe practices and where property-damage-only accidents could occur.



### NOTE

- Warnings and Cautions appear at appropriate locations throughout this manual.
- Read these carefully.



### WARNING

- An all-pole disconnection switch having a contact separation of at least 3mm in all poles should be connected in fixed wiring.
- The temperature of refrigerant circuit will be high, please keep the interconnection cable away from the copper tube.
- The appliance should not be used by children without supervision.
- This appliance can be used by children aged from 8 years and above and persons with reduced physical, sensory or mental capabilities or lack of experience and knowledge if they have been given supervision or instruction concerning use of the appliance in a safe way and understand the hazards involved. Children shall not play with the appliance. Cleaning and user maintenance shall not be made by children without supervision.
- Disconnect the power supply before cleaning and maintenance.



**DISPOSAL:** Do not dispose this product as unsorted municipal waste. Collection of such waste separately for special treatment is necessary.

- Do not dispose of electrical appliances as unsorted municipal waste, use separate collection facilities.
- Contact you local government for information regarding the collection systems available.
- If electrical appliances are disposed of in landfills or dumps, hazardous substances can leak into the groundwater and get into the food chain, damaging your health and well-being.

### 3. DIMENSIONAL DATA

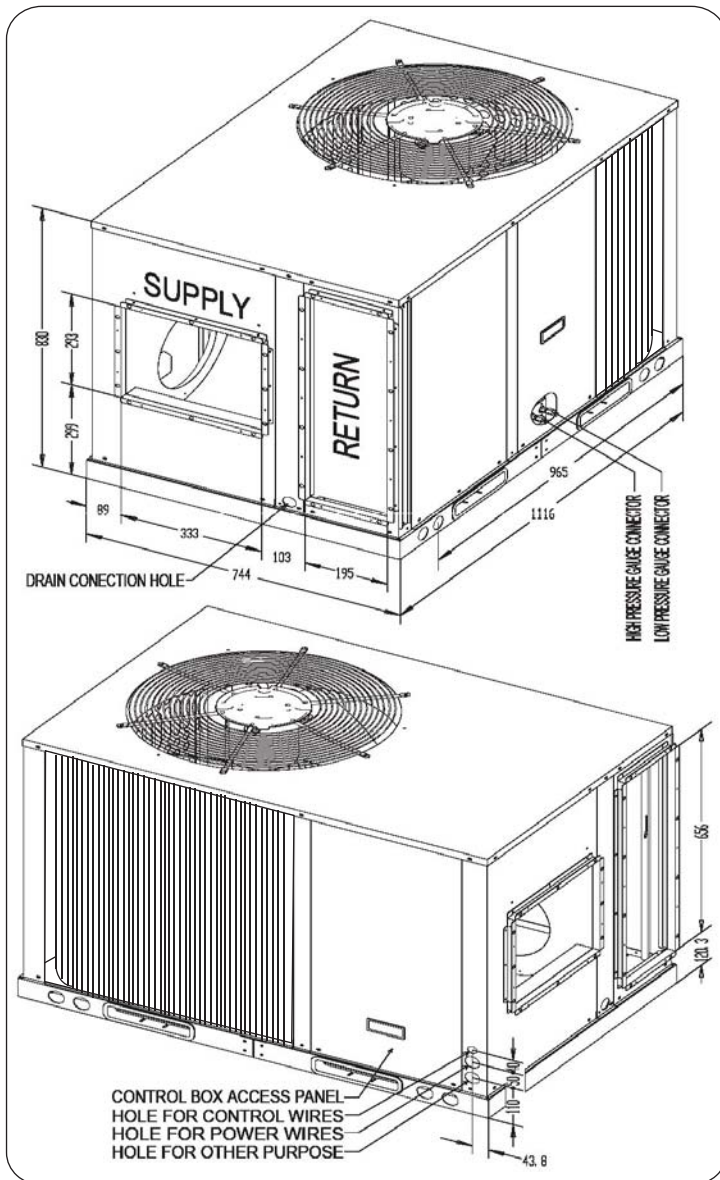

Figure 1

## 4. INSTALLATION

### 4.1 LOCATIONS AND RECOMMENDATIONS

- The unit is designed for outdoor installations only. The unit may be installed directly on wood flooring or on Class A, Class B, or Class C roof covering material.
- Location of the unit must allow service clearance around it. Clearance of the unit must be given careful consideration.
- Outdoor coils must have an unlimited supply of air.
- Check the handling facilities to ensure the safety of personnel and the unit(s).
- Caution must be taken at all times to avoid Personal injuries and/or damage to equipment.
- The unit must be mounted level for proper drainage of water through the holes in the base pan.
- The unit must not be exposed to direct roof water runoff.
- Flexible duct connectors must be of a flame retardant material. All duct work outside of the structure must be insulated and weatherproofed in accordance with local codes.
- Holes through exterior walls must be sealed in accordance with local codes.
- All fabricated outdoor ducts should be as short as possible.

### 4.2 ROOFTOP INSTALLATION

For roof top applications using a field fabricated frame and ducts, use the following procedure:

- Roof structure must be able to support the weight of the unit and its options and/or accessories. Unit must be installed on a solid level roof curb or appropriate angle iron frame.

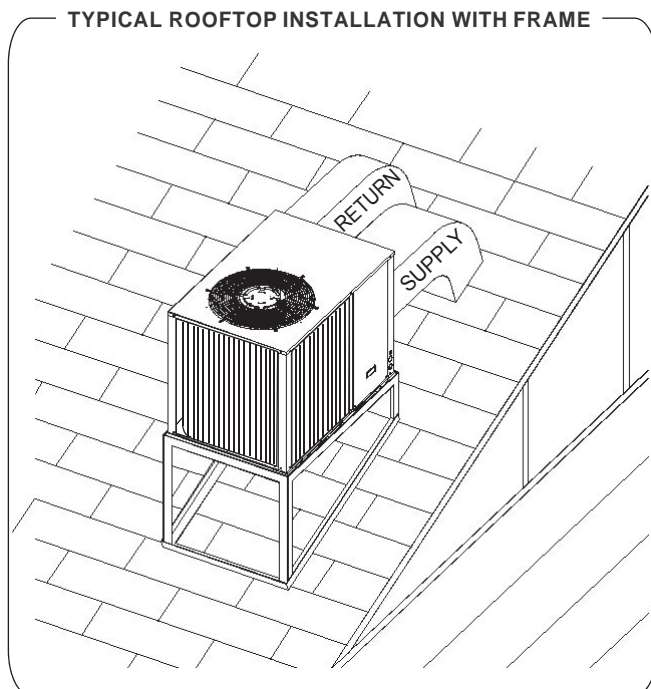

Figure 2

- The frame must be located and secured by bolting or welding to the roof. Flashing is required.
- The hole in the roof must be prepared in advance of installing the unit.
- Secure the ducts to the roof.
- Place the unit on the frame or roof curb.
- Insulate any ductwork outside of the structure with at least two (2) inches of insulation and then weatherproof. There must be a weatherproof seal where the duct enters the structure.
- Secure the unit to the frame or roof curb.
- Complete the installation according to the instructions in the following sections of this manual.

### 4.3 ON-THE-GROUND INSTALLATION

For ground level installations, the unit should be positioned on a pad with a minimum thickness of 100 mm. The length and width of the pad should be at least 150 mm greater than the unit base rails. The unit must be level on the pad. The pad must not come in contact with the structure. Be sure the outdoor portion of the supply and return air ducts are as short as possible.

Proceed with the installation as follows:

- Place the unit on the pad.
- Attach the supply and return air ducts to the unit.
- Insulate any ductwork outside of the structure with at least 2 inches of insulation and weatherproof. There must be a weatherproof seal where the duct enters the structure.
- Complete the installation according to the instructions in the following sections of this manual.

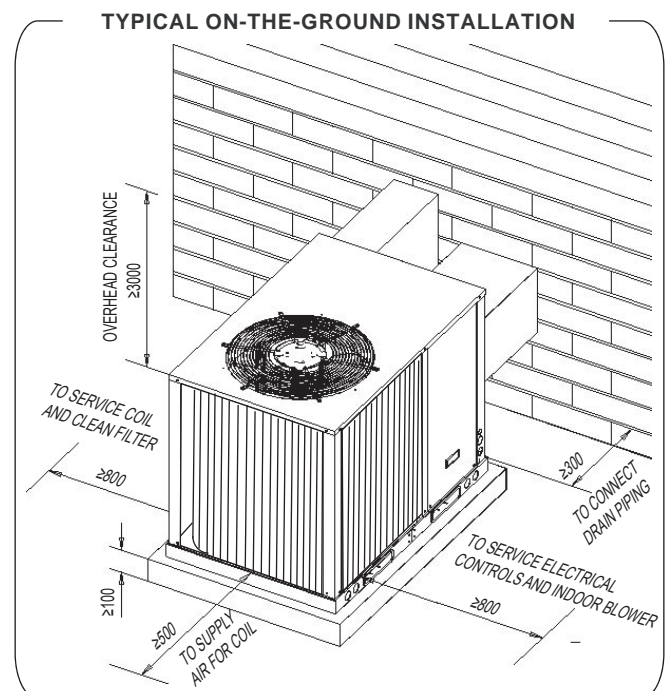

Figure 3

## 4.4 MAXIMUM FOUNDATION GRADIENT

Note: Make sure that Condensate Drain side is not higher than the other side.

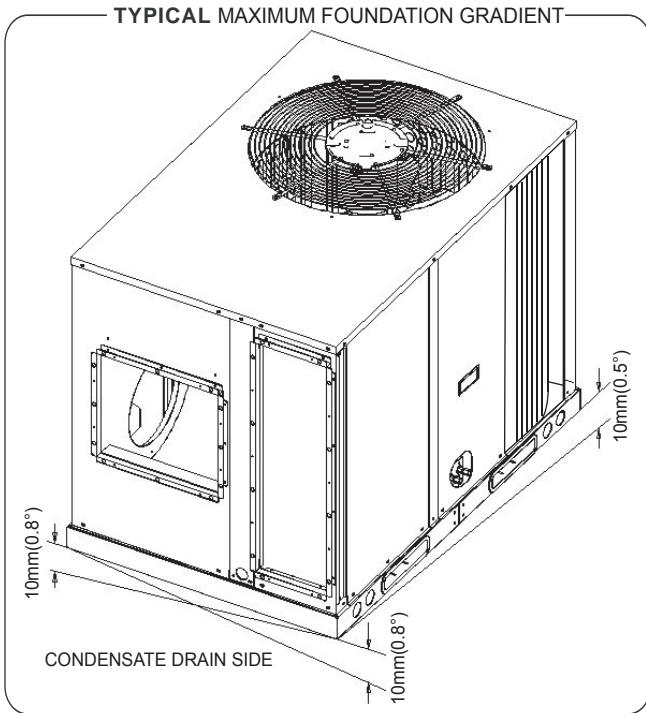

Figure 4

## 4.5 CONDENSATE DRAIN PIPING

Note: Twist drain outlet into drain connection hole, sheathe drain pipe, lock in the snap ring.

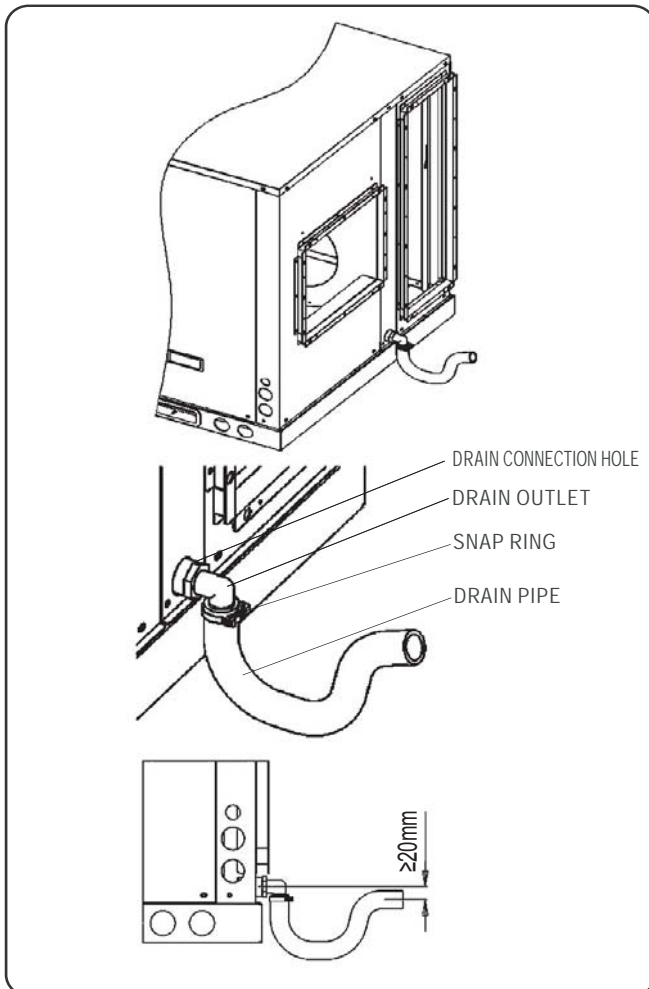

Figure 5

## 4.6 DUCTWORK

All conditioned air ductwork should be insulated to minimize heating and cooling duct losses. Use a minimum of two (2) inches of insulation with a vapor barrier. The outside ductwork must be weatherproofed between the unit and the building.

When attaching ductwork to a horizontal unit, provide a flexible watertight connection to prevent noise transmission from the unit to the ducts. The flexible connection must be indoors and made out of heavy canvas.

**NOTE**  
Do not draw the canvas taut between the solid ducts.

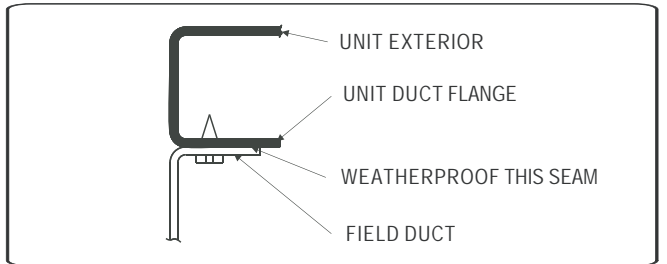

Figure 6

## 5. ELECTRICAL WIRING

- **ELECTRICAL POWER**  
It is important that proper electrical power be available for the unit. Voltage variation should remain within the limits stamped on the unit nameplate.
- **DISCONNECT SWITCH**  
Provide an approved weatherproof disconnect either on the side of the unit or within close proximity and within sight of the unit.
- **OVER CURRENT PROTECTION**  
The branch circuit feeding the unit must be protected as shown on the unit rating plate.
- **POWER WIRING**  
The power supply lines must be run in weather tight conduit to the disconnect and into the bottom of the unit control box. Provide strain relief for all conduit with suitable connectors. Provide flexible conduit supports whenever vibration transmission may cause a noise problem within the building structure. Be sure all connections are made tight.
- **CONTROL WIRING (CLASS II)**  
Low voltage control wiring should not be run in conduit with power wiring unless Class 1 wire of proper voltage rating is used. Make connections as shown on the unit wiring diagram. Do not short thermostat wires since this will damage the control-transformer.

**Suggestion: thermostat choose Non-programmed electrical thermostat series such as**  

1. Honeywell, TH5220D
2. Hailin, A3211

**IMPORTANT:** Upon completion of wiring check all electrical connections, including factory wiring within the unit, make sure all connections are tight. Replace and secure all electrical box covers and access doors before leaving the unit or turning on the power to the unit.

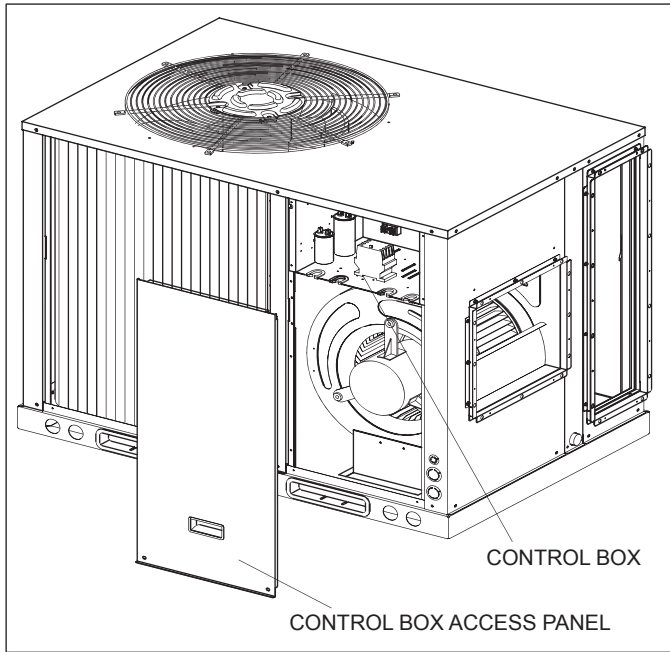

Figure 7



**NOTE**

Knock down the control box access panel, first twist off screws and then up it, the control box access panel is getting out.



**CAUTION**

If the supply cord is damaged, it must be replaced by the manufacturer or its service agent or a similarly qualified person in order to avoid a hazard.

An all-pole disconnection device which has at least 3mm separation distance in all pole and a residual current device(RCD)with the rating of above 10mA shall be incorporated in the fixed wiring according to the national rule.

The appliance shall be installed in accordance with national wiring regulations.

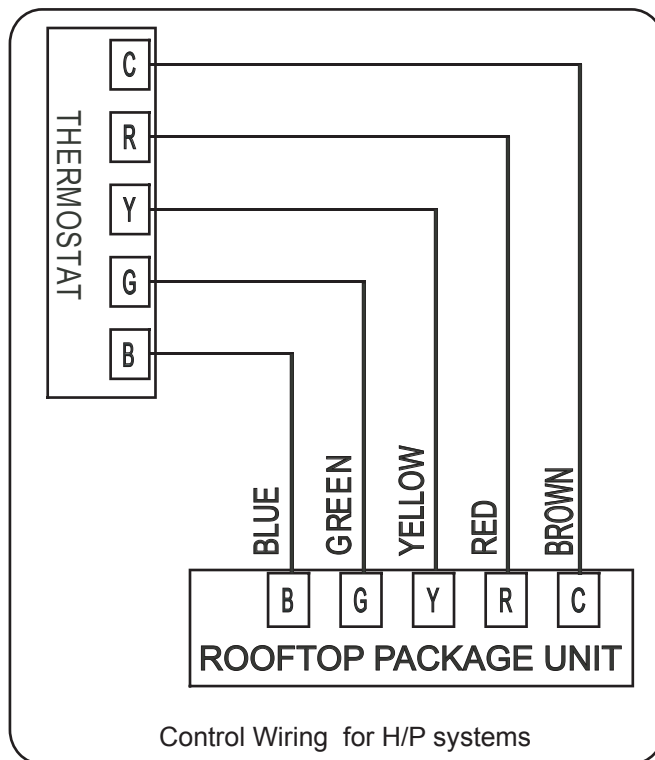
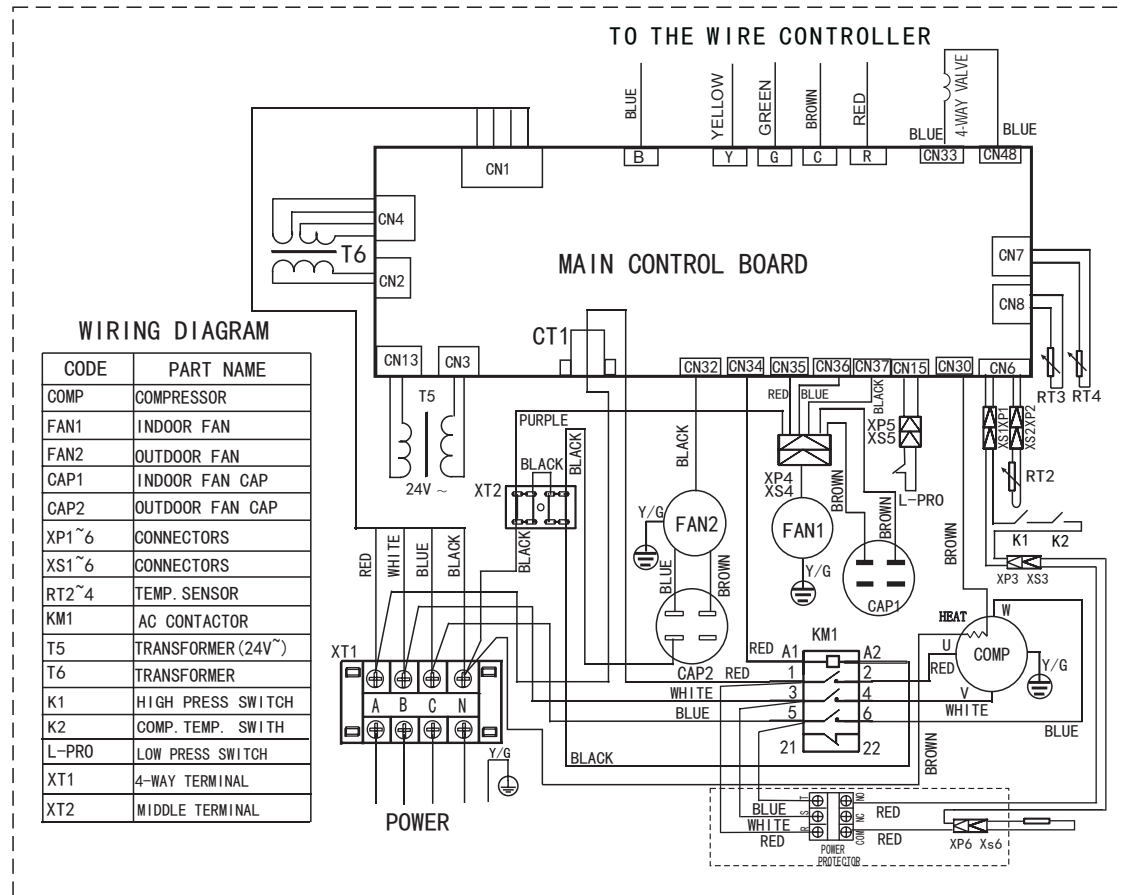
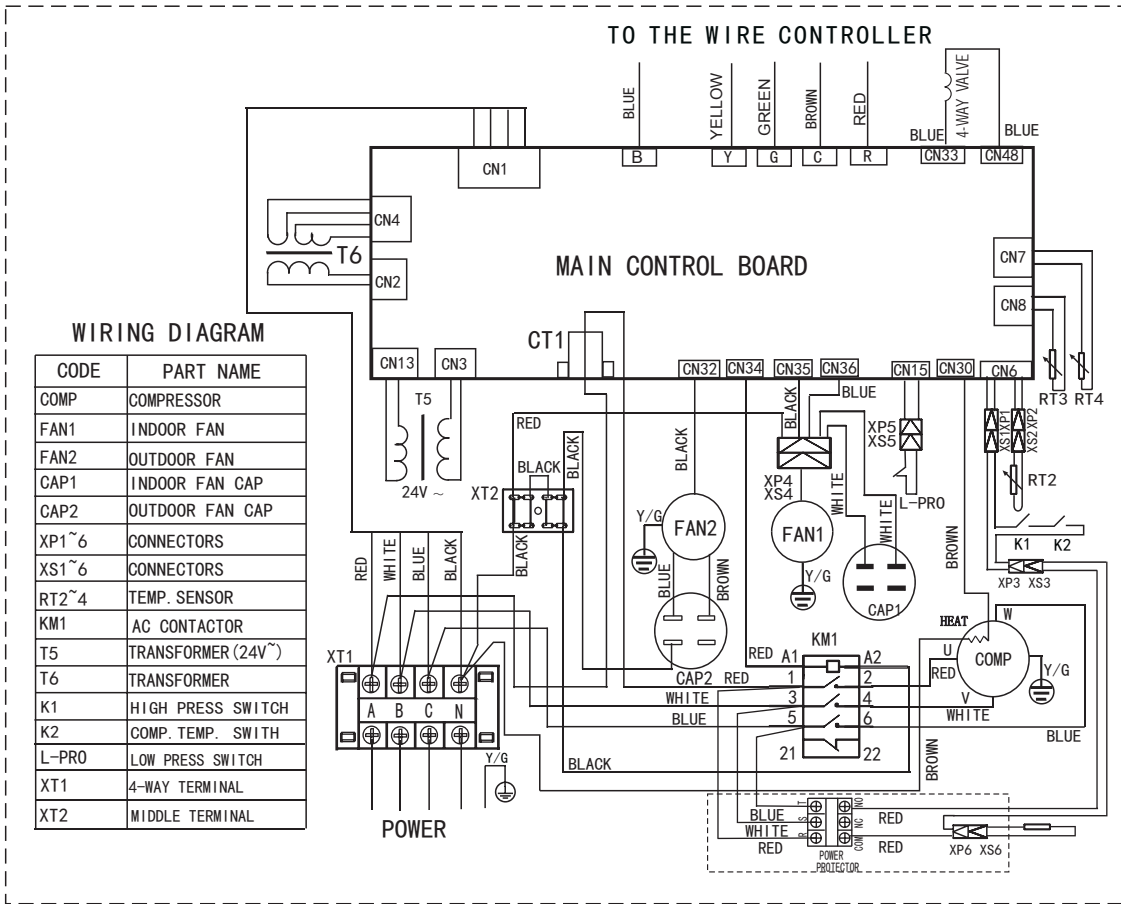

Figure 8

**Suggestion:** Thermostat choose KJR-25B or Non-programmed electrical thermostat series of Honeywell, such as TH 5220D. Wiring please refer to the Owner's Manual of the thermostat.







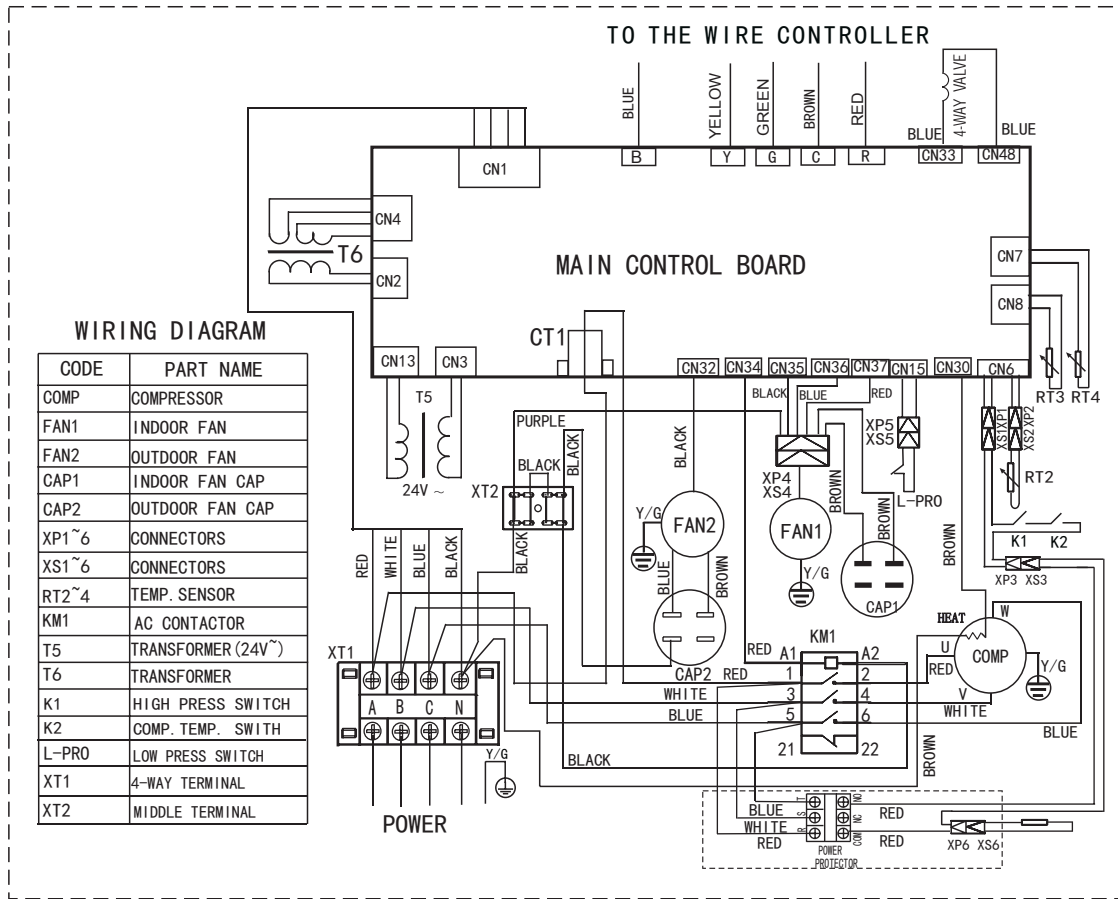

62HP,380-415V/3PH/50Hz

| TYPE                             |                    | 36HP            | 48HP/62HP       |
|----------------------------------|--------------------|-----------------|-----------------|
| POWER                            | PHASE              | 3-PHASE         | 3-PHASE         |
|                                  | FREQUENCY AND VOLT | 380-415V~, 50Hz | 380-415V~, 50Hz |
| CIRCUIT BREAKER/FUSE (A)         |                    | 20/16           | 20/16           |
| POWER WIRING (mm <sup>2</sup> )  |                    | 5×2.0           | 5×2.0           |
| SIGNAL WIRING (mm <sup>2</sup> ) |                    | 1.0×5           | 1.0×5           |

The power cord type designation is H07RN-F.

## 6. OPERATING CONDITIONS

For proper performance, run the unit under the following temperature conditions:

|                   |   |
|-------------------|---|
| Cooling operation | Outdoor temperature: 21 to 43°C   |
|                   | Room temperature: 17 to 32°C  |
|                   | Caution<br>Room relative humidity less than 80%. If the unit operates in excess of this figure, the surface of the unit may attract condensation. |
| Heating operation | Outdoor temperature: -5 to 24°C   |
|                   | Room temperature: 0 to 30°C   |

## 7. PHYSICAL DATA

Table 7-1

| Component                  |                          | Physical Data |             |             |
|----------------------------|--------------------------|---------------|-------------|-------------|
| Model                      |                          | 36            | 48          | 62          |
| ARI COOLING PERFORMANCE    | SEER                     | 10            | 10          | 10          |
|                            | Refrigerant type         | R-410A        | R-410A      | R-410A      |
| DIMENSIONS                 | Length (mm)              | 1102          | 1102        | 1102        |
|                            | Width (mm)               | 730           | 730         | 730         |
|                            | Height (mm)              | 830           | 830         | 830         |
| CONDENSER COIL DATA        | Fins per inch            | 17            | 17          | 17          |
|                            | Tube diameter (in.)      | 9/32          | 9/32        | 9/32        |
|                            | Circuitry Type           | Intertwined   | Intertwined | Intertwined |
| EVAPORATOR COIL DATA       | Rows                     | 3             | 4           | 4           |
|                            | Fins per inch            | 17            | 17          | 17          |
|                            | Tube diameter (in.)      | 9/32          | 9/32        | 9/32        |
|                            | Refrigerant control      | Orifice       | Orifice     | Orifice     |
| CONDENSER FAN DATA         | Quantity                 | 1             | 1           | 1           |
|                            | Fan diameter (mm)        | 550           | 550         | 550         |
|                            | Type                     | Prop          | Prop        | Prop        |
|                            | Drive type               | Direct        | Direct      | Direct      |
|                            | No. Speeds               | 1             | 1           | 1           |
|                            | Number of motors         | 1             | 1           | 1           |
|                            | RPM                      | 940           | 1050        | 1050        |
|                            | Nominal total CFM        | 3180          | 3600        | 3200        |
| DIRECT DRIVE EVAP FAN DATA | Quantity                 | 1             | 1           | 1           |
|                            | Fan diameter (in.)       | 11.1          | 11.1        | 11.1        |
|                            | Type                     | Centrifugal   | Centrifugal | Centrifugal |
|                            | Drive type               | Direct        | Direct      | Direct      |
|                            | No. Speeds               | 2             | 3           | 3           |
|                            | Number of motors         | 1             | 1           | 1           |
|                            | RPM                      | 850           | 1090        | 1140        |
|                            | Nominal total CFM (50Pa) | 1274          | 1689        | 1819        |

## 8. WIND PRESSURE DATA

**Table 8-1 Duct Application**

| Model Number | Motor Speed | CFM(L/S)(Watts)                           |           |           |           |           |           |           |           |
|--------------|-------------|---|-----------|-----------|-----------|-----------|-----------|-----------|-----------|
|              |             | External Static Pressure-Inches W.C.[kPa] |           |           |           |           |           |           |           |
|              |             | 0[0]                                      | 0.1[.02]  | 0.2[.05]  | 0.3[.07]  | 0.4[.10]  | 0.5[.12]  | 0.6[.15]  | 0.7[.17]  |
| 36HP         | Low         | CFM(L/S)                                  | 1380(651) | 1282(605) | 1167(551) | 1006(475) | 889(420)  |           |           |
|              |             | RPM                                       | 772       | 797       | 822       | 849       | 805       |           |           |
|              |             | Watts                                     | 304       | 291       | 274       | 256       | 243       |           |           |
|              |             | Amps                                      | 1.4       | 1.3       | 1.3       | 1.2       | 1.1       |           |           |
|              | Middle      | CFM(L/S)                                  |           |           |           |           |           |           |           |
|              |             | RPM                                       |           |           |           |           |           |           |           |
|              |             | Watts                                     |           |           |           |           |           |           |           |
|              |             | Amps                                      |           |           |           |           |           |           |           |
|              | High        | CFM(L/S)                                  | 1464(691) | 1378(650) | 1274(601) | 1070(505) | 947(447)  | 820(387)  |           |
|              |             | RPM                                       | 817       | 830       | 848       | 873       | 885       | 898       |           |
|              |             | Watts                                     | 343       | 331       | 315       | 292       | 278       | 263       |           |
|              |             | Amps                                      | 1.56      | 1.5       | 1.4       | 1.3       | 1.3       | 1.2       |           |
| 48HP         | Low         | CFM(L/S)                                  | 1651(779) | 1601(756) | 1554(733) | 1503(709) | 1444(682) | 1375(649) | 1290(609) |
|              |             | RPM                                       | 985       | 1015      | 1043      | 1073      | 1099      | 1121      | 1140      |
|              |             | Watts                                     | 732       | 720       | 706       | 691       | 675       | 659       | 640       |
|              |             | Amps                                      | 3.4       | 3.3       | 3.2       | 3.2       | 3.1       | 3.0       | 3.0       |
|              | Middle      | CFM(L/S)                                  | 1786(843) | 1733(818) | 1689(797) | 1641(775) | 1583(747) | 1521(718) | 1450(684) |
|              |             | RPM                                       | 1039      | 1066      | 1088      | 1114      | 1145      | 1164      | 1181      |
|              |             | Watts                                     | 842       | 825       | 812       | 796       | 777       | 762       | 736       |
|              |             | Amps                                      | 3.9       | 3.8       | 3.7       | 3.7       | 3.6       | 3.5       | 3.5       |
|              | High        | CFM(L/S)                                  | 1925(909) | 1869(882) | 1819(859) | 1767(834) | 1717(810) | 1656(782) | 1580(746) |
|              |             | RPM                                       | 1100      | 1117      | 1142      | 1160      | 1192      | 1206      | 1221      |
|              |             | Watts                                     | 967       | 950       | 931       | 914       | 895       | 875       | 848       |
|              |             | Amps                                      | 4.4       | 4.4       | 4.3       | 4.2       | 4.1       | 4.0       | 3.9       |
| 62HP         | Low         | CFM(L/S)                                  | 1651(779) | 1601(756) | 1554(733) | 1503(709) | 1444(682) |           |           |
|              |             | RPM                                       | 985       | 1015      | 1043      | 1073      | 1099      |           |           |
|              |             | Watts                                     | 732       | 720       | 706       | 691       | 675       |           |           |
|              |             | Amps                                      | 3.4       | 3.3       | 3.2       | 3.2       | 3.1       |           |           |
|              | Middle      | CFM(L/S)                                  | 1786(843) | 1733(818) | 1689(797) | 1641(775) | 1583(747) | 1521(718) |           |
|              |             | RPM                                       | 1039      | 1066      | 1088      | 1114      | 1145      | 1164      |           |
|              |             | Watts                                     | 842       | 825       | 812       | 796       | 777       | 762       |           |
|              |             | Amps                                      | 3.9       | 3.8       | 3.7       | 3.7       | 3.6       | 3.5       |           |
|              | High        | CFM(L/S)                                  | 1925(909) | 1869(882) | 1819(859) | 1767(834) | 1717(810) | 1656(782) | 1580(746) |
|              |             | RPM                                       | 1100      | 1117      | 1142      | 1160      | 1192      | 1206      | 1221      |
|              |             | Watts                                     | 967       | 950       | 931       | 914       | 895       | 875       | 848       |
|              |             | Amps                                      | 4.4       | 4.4       | 4.3       | 4.2       | 4.1       | 4.0       | 3.9       |

## 9. PERFORMANCE DATA

### COOLING PERFORMANCE DATA—36HP(380V, 50Hz, 3Ph)

| Air Flow (CFM)      |          | 1370 |      |      |      |      | 1500 |      |      |      |      |
|---------------------|----------|------|------|------|------|------|------|------|------|------|------|
|                     | Ent (DB) | (°F) | 72   | 75   | 78   | 80   | 72   | 75   | 78   | 80   |      |
| Ambient Temperature | 85       | 63   | TC   | 27.5 | 30.9 | 33.9 | 35.7 | 28.1 | 31.5 | 34.6 | 36.4 |
|                     |          |      | SC   | 20.8 | 24.1 | 27.1 | 28.9 | 21.2 | 24.6 | 27.7 | 29.5 |
|                     |          |      | PI   | 2.69 | 2.71 | 2.72 | 2.73 | 2.72 | 2.73 | 2.75 | 2.76 |
|                     |          | 67   | TC   | 28.6 | 32.3 | 35.9 | 38.0 | 29.2 | 33.0 | 36.6 | 38.8 |
|                     |          |      | SC   | 16.5 | 20.2 | 23.7 | 25.9 | 16.8 | 20.6 | 24.2 | 26.4 |
|                     |          |      | PI   | 2.71 | 2.72 | 2.74 | 2.75 | 2.74 | 2.75 | 2.77 | 2.78 |
|                     | 71       | TC   | 29.7 | 33.7 | 37.5 | 39.9 | 30.3 | 34.4 | 38.3 | 40.7 |      |
|                     |          | SC   | 11.6 | 15.6 | 19.4 | 21.8 | 11.8 | 15.9 | 19.8 | 22.2 |      |
|                     |          | PI   | 2.72 | 2.73 | 2.75 | 2.76 | 2.75 | 2.76 | 2.78 | 2.79 |      |
|                     | 95       | 63   | TC   | 24.2 | 27.7 | 31.0 | 32.9 | 24.7 | 28.3 | 31.6 | 33.6 |
|                     |          |      | SC   | 20.0 | 23.5 | 26.8 | 28.7 | 20.4 | 24.0 | 27.3 | 29.3 |
|                     |          |      | PI   | 2.96 | 2.98 | 2.99 | 3.01 | 2.99 | 3.01 | 3.02 | 3.04 |
|                     |          | 67   | TC   | 26.3 | 30.1 | 33.7 | 35.3 | 26.8 | 30.7 | 34.4 | 36.0 |
|                     |          |      | SC   | 15.7 | 19.5 | 23.1 | 24.7 | 16.0 | 19.9 | 23.6 | 25.2 |
|                     |          |      | PI   | 2.98 | 3.00 | 3.01 | 3.03 | 3.01 | 3.03 | 3.04 | 3.06 |
|                     |          | 71   | TC   | 27.0 | 30.9 | 34.7 | 37.1 | 27.5 | 31.5 | 35.4 | 37.9 |
|                     |          |      | SC   | 10.9 | 14.8 | 18.6 | 21.1 | 11.1 | 15.1 | 19.0 | 21.5 |
|                     |          |      | PI   | 2.99 | 3.01 | 3.02 | 3.04 | 3.02 | 3.04 | 3.05 | 3.07 |
|                     | 105      | 63   | TC   | 21.1 | 24.7 | 28.0 | 30.2 | 21.5 | 25.2 | 28.6 | 30.8 |
|                     |          |      | SC   | 19.1 | 22.7 | 26.1 | 28.2 | 19.5 | 23.2 | 26.6 | 28.8 |
|                     |          |      | PI   | 3.24 | 3.25 | 3.27 | 3.29 | 3.27 | 3.29 | 3.30 | 3.32 |
|                     |          | 67   | TC   | 22.6 | 26.5 | 30.2 | 32.5 | 23.1 | 27.0 | 30.8 | 33.2 |
|                     |          |      | SC   | 14.8 | 18.6 | 22.3 | 24.7 | 15.1 | 19.0 | 22.8 | 25.2 |
|                     |          |      | PI   | 3.26 | 3.27 | 3.29 | 3.31 | 3.29 | 3.31 | 3.32 | 3.34 |
| 71                  |          | TC   | 24.3 | 28.0 | 31.9 | 34.4 | 24.8 | 28.6 | 32.5 | 35.1 |      |
|                     |          | SC   | 10.2 | 13.9 | 17.7 | 20.3 | 10.4 | 14.2 | 18.1 | 20.7 |      |
|                     |          | PI   | 3.27 | 3.28 | 3.30 | 3.32 | 3.30 | 3.32 | 3.33 | 3.35 |      |
| 115                 | 63       | TC   | 18.2 | 21.9 | 25.3 | 27.4 | 18.6 | 22.3 | 25.8 | 28.0 |      |
|                     |          | SC   | 18.1 | 21.8 | 25.2 | 27.3 | 18.5 | 22.2 | 25.7 | 27.9 |      |
|                     |          | PI   | 3.51 | 3.53 | 3.55 | 3.56 | 3.55 | 3.56 | 3.58 | 3.60 |      |
|                     | 67       | TC   | 19.8 | 23.6 | 27.3 | 29.8 | 20.2 | 24.1 | 27.9 | 30.4 |      |
|                     |          | SC   | 13.8 | 17.6 | 21.4 | 23.8 | 14.1 | 18.0 | 21.8 | 24.3 |      |
|                     |          | PI   | 3.53 | 3.55 | 3.57 | 3.58 | 3.57 | 3.58 | 3.60 | 3.62 |      |
|                     | 71       | TC   | 21.8 | 25.3 | 29.1 | 31.7 | 22.2 | 25.8 | 29.7 | 32.3 |      |
|                     |          | SC   | 9.5  | 13.0 | 16.9 | 19.4 | 9.7  | 13.3 | 17.2 | 19.8 |      |
|                     |          | PI   | 3.54 | 3.56 | 3.58 | 3.59 | 3.58 | 3.59 | 3.61 | 3.63 |      |

Notes:  
 1.All capacities are net and have considered indoor fan heat.  
 2.TC=Total Capacity. (Unit:1000Btu/h)  
 3.SC=SensibleCapacity. (Unit:1000Btu/h)  
 4.different air volume in the above table, need to adjust in the field.

### HEATING PERFORMANCE DATA—36HP(380V, 50Hz, 3Ph)

| Net Capacities(kW)-1400 CFM |  |      |      |      |  |      |      |      |
|-----------------------------|--|------|------|------|--|------|------|------|
|                             | Peak Net Heating(kW) at Indicated Dry Bulb(°F) |      |      |      | Peak Total Power(KW) at Indicated Dry Bulb(°F) |      |      |      |
| Outdoor Temp(°F) 70% RH     | 60   | 70   | 75   | 80   | 60   | 70   | 75   | 80   |
| 17                          | 20.6   | 20.2 | 20.0 | 19.8 | 2.41   | 2.55 | 2.62 | 2.69 |
| 22                          | 22.8   | 22.3 | 22.1 | 21.9 | 2.53   | 2.68 | 2.75 | 2.83 |
| 27                          | 25.0   | 24.5 | 24.2 | 24.0 | 2.64   | 2.80 | 2.88 | 2.96 |
| 32                          | 26.8   | 26.2 | 26.0 | 25.7 | 2.76   | 2.93 | 3.01 | 3.09 |
| 37                          | 29.7   | 29.1 | 28.8 | 28.5 | 2.91   | 3.08 | 3.17 | 3.26 |
| 42                          | 33.8   | 33.1 | 32.8 | 32.5 | 3.06   | 3.24 | 3.34 | 3.43 |
| 47                          | 38.2   | 37.5 | 37.2 | 36.8 | 3.21   | 3.40 | 3.50 | 3.60 |
| 52                          | 41.1   | 40.4 | 40.0 | 39.6 | 3.34   | 3.54 | 3.64 | 3.75 |
| 57                          | 44.1   | 43.3 | 42.9 | 42.5 | 3.47   | 3.69 | 3.79 | 3.90 |
| 62                          | 47.0   | 46.2 | 45.7 | 45.3 | 3.61   | 3.83 | 3.94 | 4.05 |
| 67                          | 49.9   | 49.0 | 48.6 | 48.2 | 3.74   | 3.97 | 4.08 | 4.20 |
| 72                          | 52.8   | 51.9 | 51.5 | 51.0 | 3.87   | 4.11 | 4.23 | 4.35 |

- Notes: 1. For other airflows, see heating capacity correction factor tables.  
 2. Heating capacities and power are integrated to include the effects of defrost in the frost region.

COOLING PERFORMANCE DATA—48HP(380V, 50Hz, 3Ph)

| Air Flow (CFM)      |          |      | 1650 |      |      |      | 1750 |      |      |      | 1950 |      |      |      |      |
|---------------------|----------|------|------|------|------|------|------|------|------|------|------|------|------|------|------|
| Ambient Temperature | Ent (DB) | (°F) | 72   | 75   | 78   | 80   | 72   | 75   | 78   | 80   | 72   | 75   | 78   | 80   |      |
|                     |          |      | 85   | 63   | TC   | 36.7 | 41.1 | 45.1 | 47.5 | 37.4 | 41.9 | 46.0 | 48.5 | 38.1 | 42.7 |
| SC                  | 27.6     | 32.0 |      |      | 36.1 | 38.5 | 28.2 | 32.7 | 36.8 | 39.3 | 28.8 | 33.4 | 37.5 | 40.1 |      |
| PI                  | 4.16     | 4.19 |      |      | 4.21 | 4.23 | 4.21 | 4.23 | 4.25 | 4.27 | 4.25 | 4.27 | 4.29 | 4.31 |      |
| 67                  | TC       | 38.2 |      | 43.2 | 47.8 | 50.7 | 39.0 | 44.1 | 48.8 | 51.7 | 39.8 | 45.0 | 49.8 | 52.7 |      |
|                     | SC       | 22.0 |      | 27.0 | 31.6 | 34.4 | 22.4 | 27.5 | 32.2 | 35.1 | 22.8 | 28.1 | 32.8 | 35.8 |      |
|                     | PI       | 4.19 |      | 4.21 | 4.24 | 4.26 | 4.24 | 4.26 | 4.28 | 4.30 | 4.28 | 4.30 | 4.32 | 4.34 |      |
| 71                  | TC       | 39.6 |      | 44.9 | 50.0 | 53.2 | 40.4 | 45.8 | 51.0 | 54.3 | 41.2 | 46.7 | 52.0 | 55.4 |      |
|                     | SC       | 15.5 |      | 20.8 | 25.9 | 29.1 | 15.8 | 21.2 | 26.4 | 29.7 | 16.1 | 21.6 | 26.9 | 30.3 |      |
|                     | PI       | 4.22 |      | 4.24 | 4.27 | 4.29 | 4.27 | 4.29 | 4.31 | 4.33 | 4.31 | 4.33 | 4.35 | 4.37 |      |
| 95                  | 63       | TC   |      | 32.2 | 36.9 | 41.3 | 43.9 | 32.9 | 37.7 | 42.1 | 44.8 | 33.6 | 38.5 | 42.9 | 45.7 |
|                     |          | SC   |      | 26.7 | 31.4 | 35.7 | 38.3 | 27.2 | 32.0 | 36.4 | 39.1 | 27.7 | 32.6 | 37.1 | 39.9 |
|                     |          | PI   |      | 4.60 | 4.63 | 4.65 | 4.67 | 4.65 | 4.67 | 4.70 | 4.72 | 4.70 | 4.72 | 4.74 | 4.77 |
|                     | 67       | TC   |      | 35.0 | 40.1 | 44.9 | 47.0 | 35.7 | 40.9 | 45.8 | 48.0 | 36.4 | 41.7 | 46.7 | 49.0 |
|                     |          | SC   |      | 20.9 | 26.0 | 30.8 | 32.9 | 21.3 | 26.5 | 31.4 | 33.6 | 21.7 | 27.0 | 32.0 | 34.3 |
|                     |          | PI   |      | 4.63 | 4.66 | 4.68 | 4.70 | 4.68 | 4.70 | 4.73 | 4.75 | 4.73 | 4.75 | 4.77 | 4.80 |
|                     | 71       | TC   |      | 35.9 | 41.1 | 46.2 | 49.5 | 36.6 | 41.9 | 47.1 | 50.5 | 37.3 | 42.7 | 48.0 | 51.5 |
|                     |          | SC   |      | 14.5 | 19.7 | 24.8 | 28.1 | 14.8 | 20.1 | 25.3 | 28.7 | 15.1 | 20.5 | 25.8 | 29.3 |
|                     |          | PI   |      | 4.65 | 4.68 | 4.70 | 4.72 | 4.70 | 4.72 | 4.75 | 4.77 | 4.75 | 4.77 | 4.79 | 4.82 |
| 105                 | 63       | TC   |      | 28.1 | 32.9 | 37.4 | 40.3 | 28.7 | 33.6 | 38.2 | 41.1 | 29.3 | 34.3 | 39.0 | 41.9 |
|                     |          | SC   |      | 25.5 | 30.3 | 34.8 | 37.6 | 26.0 | 30.9 | 35.5 | 38.4 | 26.5 | 31.5 | 36.2 | 39.2 |
|                     |          | PI   |      | 5.03 | 5.06 | 5.08 | 5.11 | 5.08 | 5.11 | 5.13 | 5.16 | 5.13 | 5.16 | 5.19 | 5.21 |
|                     | 67       | TC   |      | 30.2 | 35.3 | 40.3 | 43.4 | 30.8 | 36.0 | 41.1 | 44.3 | 31.4 | 36.7 | 41.9 | 45.2 |
|                     |          | SC   |      | 19.7 | 24.8 | 29.8 | 32.9 | 20.1 | 25.3 | 30.4 | 33.6 | 20.5 | 25.8 | 31.0 | 34.3 |
|                     |          | PI   |      | 5.06 | 5.09 | 5.11 | 5.14 | 5.11 | 5.14 | 5.16 | 5.19 | 5.16 | 5.19 | 5.22 | 5.24 |
|                     | 71       | TC   | 32.4 | 37.4 | 42.5 | 45.9 | 33.1 | 38.2 | 43.4 | 46.8 | 33.8 | 39.0 | 44.3 | 47.7 |      |
|                     |          | SC   | 13.6 | 18.6 | 23.7 | 27.0 | 13.9 | 19.0 | 24.2 | 27.6 | 14.2 | 19.4 | 24.7 | 28.2 |      |
|                     |          | PI   | 5.09 | 5.12 | 5.14 | 5.17 | 5.14 | 5.17 | 5.19 | 5.22 | 5.19 | 5.22 | 5.25 | 5.27 |      |
| 115                 | 63       | TC   | 24.4 | 29.2 | 33.8 | 36.7 | 24.9 | 29.8 | 34.5 | 37.4 | 25.4 | 30.4 | 35.2 | 38.1 |      |
|                     |          | SC   | 24.2 | 29.0 | 33.6 | 36.5 | 24.7 | 29.6 | 34.3 | 37.2 | 25.2 | 30.2 | 35.0 | 37.9 |      |
|                     |          | PI   | 5.47 | 5.50 | 5.53 | 5.55 | 5.53 | 5.55 | 5.58 | 5.61 | 5.58 | 5.61 | 5.64 | 5.67 |      |
|                     | 67       | TC   | 26.6 | 31.6 | 36.6 | 39.8 | 27.1 | 32.2 | 37.3 | 40.6 | 27.6 | 32.8 | 38.0 | 41.4 |      |
|                     |          | SC   | 18.5 | 23.5 | 28.5 | 31.8 | 18.9 | 24.0 | 29.1 | 32.4 | 19.3 | 24.5 | 29.7 | 33.0 |      |
|                     |          | PI   | 5.49 | 5.52 | 5.55 | 5.57 | 5.55 | 5.57 | 5.60 | 5.63 | 5.60 | 5.63 | 5.66 | 5.69 |      |
|                     | 71       | TC   | 29.0 | 33.8 | 38.8 | 42.2 | 29.6 | 34.5 | 39.6 | 43.1 | 30.2 | 35.2 | 40.4 | 44.0 |      |
|                     |          | SC   | 12.6 | 17.4 | 22.4 | 25.9 | 12.9 | 17.8 | 22.9 | 26.4 | 13.2 | 18.2 | 23.4 | 26.9 |      |
|                     |          | PI   | 5.52 | 5.55 | 5.58 | 5.60 | 5.58 | 5.60 | 5.63 | 5.66 | 5.63 | 5.66 | 5.69 | 5.72 |      |

Notes:  
 1. All capacities are net and have considered indoor fan heat.  
 2. TC=Total Capacity. (Unit:1000Btu/h)  
 3. SC=SensibleCapacity. (Unit:1000Btu/h)  
 4. different air volume in the above table, need to adjust in the field.

HEATING PERFORMANCE DATA—48HP(380V, 50Hz, 3Ph)

| Net Capacities(kW)-1700 CFM |  |      |      |      |  |      |      |      |
|-----------------------------|--|------|------|------|--|------|------|------|
| Outdoor Temp(°F) 70% RH     | Peak Net Heating(kW) at Indicated Dry Bulb(°F) |      |      |      | Peak Total Power(KW) at Indicated Dry Bulb(°F) |      |      |      |
|                             | 60   | 70   | 75   | 80   | 60   | 70   | 75   | 80   |
| 17                          | 27.8   | 27.2 | 26.9 | 26.6 | 3.62   | 3.83 | 3.94 | 4.04 |
| 22                          | 30.8   | 30.2 | 29.9 | 29.6 | 3.79   | 4.01 | 4.12 | 4.23 |
| 27                          | 33.9   | 33.2 | 32.9 | 32.6 | 3.95   | 4.18 | 4.30 | 4.41 |
| 32                          | 36.5   | 35.7 | 35.4 | 35.0 | 4.11   | 4.36 | 4.48 | 4.60 |
| 37                          | 40.6   | 39.8 | 39.4 | 39.0 | 4.32   | 4.58 | 4.71 | 4.84 |
| 42                          | 46.3   | 45.4 | 44.9 | 44.5 | 4.54   | 4.80 | 4.94 | 5.07 |
| 47                          | 52.4   | 51.5 | 51.0 | 50.6 | 4.75   | 5.03 | 5.17 | 5.31 |
| 52                          | 56.6   | 55.6 | 55.0 | 54.5 | 4.94   | 5.23 | 5.38 | 5.52 |
| 57                          | 60.7   | 59.6 | 59.1 | 58.5 | 5.12   | 5.43 | 5.58 | 5.73 |
| 62                          | 64.8   | 63.7 | 63.1 | 62.5 | 5.31   | 5.63 | 5.79 | 5.95 |
| 67                          | 68.9   | 67.7 | 67.1 | 66.5 | 5.50   | 5.83 | 5.99 | 6.16 |
| 72                          | 73.0   | 71.8 | 71.1 | 70.5 | 5.69   | 6.03 | 6.20 | 6.37 |

Notes: 1. For other airflows, see heating capacity correction factor tables.  
 2. Heating capacities and power are integrated to include the effects of defrost in the frost region.

COOLING PERFORMANCE DATA—62HP(380V, 50Hz, 3Ph)

| Air Flow (CFM)      |     |      | 1650 |      |      |      | 1750 |      |      |      | 1950 |      |      |      |      |
|---------------------|-----|------|------|------|------|------|------|------|------|------|------|------|------|------|------|
| Ent (DB)            |     | (°F) | 72   | 75   | 78   | 80   | 72   | 75   | 78   | 80   | 72   | 75   | 78   | 80   |      |
| Ambient Temperature | 85  | 63   | TC   | 43.4 | 48.6 | 53.4 | 56.3 | 44.3 | 49.6 | 54.5 | 57.4 | 45.2 | 50.6 | 55.6 | 58.6 |
|                     |     |      | SC   | 32.7 | 37.9 | 42.7 | 45.6 | 33.4 | 38.7 | 43.6 | 46.6 | 34.1 | 39.5 | 44.5 | 47.5 |
|                     |     |      | PI   | 4.92 | 4.95 | 4.97 | 5.00 | 4.97 | 5.00 | 5.02 | 5.05 | 5.02 | 5.05 | 5.07 | 5.10 |
|                     |     | 67   | TC   | 45.2 | 51.1 | 56.5 | 60.0 | 46.2 | 52.1 | 57.7 | 61.3 | 47.1 | 53.2 | 58.9 | 62.5 |
|                     |     |      | SC   | 26.0 | 31.9 | 37.3 | 40.8 | 26.6 | 32.5 | 38.1 | 41.7 | 27.1 | 33.2 | 38.9 | 42.5 |
|                     |     |      | PI   | 4.96 | 4.99 | 5.01 | 5.04 | 5.01 | 5.04 | 5.06 | 5.09 | 5.06 | 5.09 | 5.11 | 5.14 |
|                     |     | 71   | TC   | 46.8 | 53.2 | 59.1 | 63.0 | 47.8 | 54.3 | 60.4 | 64.3 | 48.8 | 55.4 | 61.6 | 65.6 |
|                     |     |      | SC   | 18.3 | 24.7 | 30.6 | 34.5 | 18.7 | 25.2 | 31.3 | 35.2 | 19.1 | 25.7 | 31.9 | 35.9 |
|                     |     |      | PI   | 4.99 | 5.02 | 5.04 | 5.07 | 5.04 | 5.07 | 5.09 | 5.12 | 5.09 | 5.12 | 5.14 | 5.17 |
|                     | 95  | 63   | TC   | 38.2 | 43.7 | 48.8 | 51.9 | 39.0 | 44.6 | 49.8 | 53.0 | 39.8 | 45.5 | 50.8 | 54.1 |
|                     |     |      | SC   | 31.6 | 37.1 | 42.1 | 45.3 | 32.2 | 37.8 | 43.0 | 46.3 | 32.9 | 38.6 | 43.9 | 47.2 |
|                     |     |      | PI   | 5.44 | 5.46 | 5.49 | 5.52 | 5.49 | 5.52 | 5.55 | 5.57 | 5.55 | 5.57 | 5.60 | 5.63 |
|                     |     | 67   | TC   | 41.4 | 47.4 | 53.2 | 55.7 | 42.2 | 48.4 | 54.3 | 56.8 | 43.1 | 49.4 | 55.4 | 58.0 |
|                     |     |      | SC   | 24.7 | 30.7 | 36.5 | 39.0 | 25.2 | 31.4 | 37.2 | 39.8 | 25.7 | 32.0 | 38.0 | 40.6 |
|                     |     |      | PI   | 5.46 | 5.49 | 5.52 | 5.55 | 5.52 | 5.55 | 5.58 | 5.60 | 5.58 | 5.60 | 5.63 | 5.66 |
|                     |     | 71   | TC   | 42.6 | 48.8 | 54.8 | 58.7 | 43.5 | 49.8 | 56.0 | 59.9 | 44.4 | 50.8 | 57.1 | 61.1 |
|                     |     |      | SC   | 17.3 | 23.4 | 29.5 | 33.3 | 17.6 | 23.9 | 30.1 | 34.0 | 18.0 | 24.4 | 30.7 | 34.7 |
|                     |     |      | PI   | 5.50 | 5.53 | 5.56 | 5.59 | 5.56 | 5.59 | 5.61 | 5.64 | 5.61 | 5.64 | 5.67 | 5.70 |
|                     | 105 | 63   | TC   | 33.3 | 39.0 | 44.4 | 47.6 | 34.0 | 39.8 | 45.3 | 48.6 | 34.7 | 40.6 | 46.2 | 49.6 |
|                     |     |      | SC   | 30.1 | 35.8 | 41.2 | 44.4 | 30.8 | 36.6 | 42.0 | 45.4 | 31.4 | 37.3 | 42.9 | 46.3 |
|                     |     |      | PI   | 5.95 | 5.98 | 6.01 | 6.04 | 6.01 | 6.04 | 6.07 | 6.10 | 6.07 | 6.10 | 6.13 | 6.16 |
|                     |     | 67   | TC   | 35.7 | 41.8 | 47.6 | 51.4 | 36.5 | 42.6 | 48.6 | 52.4 | 37.2 | 43.5 | 49.6 | 53.5 |
|                     |     |      | SC   | 23.3 | 29.4 | 35.2 | 39.0 | 23.8 | 30.0 | 36.0 | 39.8 | 24.3 | 30.6 | 36.7 | 40.6 |
|                     |     |      | PI   | 5.98 | 6.01 | 6.04 | 6.07 | 6.04 | 6.07 | 6.10 | 6.13 | 6.10 | 6.13 | 6.16 | 6.19 |
| 71                  |     | TC   | 38.4 | 44.4 | 50.4 | 54.3 | 39.2 | 45.3 | 51.5 | 55.5 | 40.0 | 46.2 | 52.5 | 56.6 |      |
|                     |     | SC   | 16.1 | 22.1 | 28.1 | 32.1 | 16.5 | 22.5 | 28.7 | 32.7 | 16.8 | 23.0 | 29.3 | 33.4 |      |
|                     |     | PI   | 6.00 | 6.03 | 6.07 | 6.10 | 6.07 | 6.10 | 6.13 | 6.16 | 6.13 | 6.16 | 6.19 | 6.22 |      |
| 115                 | 63  | TC   | 28.7 | 34.5 | 39.9 | 43.3 | 29.3 | 35.2 | 40.8 | 44.2 | 29.9 | 35.9 | 41.6 | 45.1 |      |
|                     |     | SC   | 28.5 | 34.3 | 39.7 | 43.1 | 29.1 | 35.0 | 40.6 | 44.0 | 29.7 | 35.7 | 41.4 | 44.9 |      |
|                     |     | PI   | 6.46 | 6.49 | 6.52 | 6.56 | 6.52 | 6.56 | 6.59 | 6.62 | 6.59 | 6.62 | 6.66 | 6.69 |      |
|                     | 67  | TC   | 31.4 | 37.3 | 43.3 | 47.0 | 32.0 | 38.1 | 44.2 | 48.0 | 32.7 | 38.9 | 45.1 | 49.0 |      |
|                     |     | SC   | 21.9 | 27.8 | 33.8 | 37.5 | 22.3 | 28.4 | 34.5 | 38.3 | 22.8 | 29.0 | 35.2 | 39.1 |      |
|                     |     | PI   | 6.49 | 6.52 | 6.55 | 6.59 | 6.55 | 6.59 | 6.62 | 6.65 | 6.62 | 6.65 | 6.69 | 6.72 |      |
|                     | 71  | TC   | 34.5 | 40.0 | 46.0 | 50.0 | 35.2 | 40.9 | 46.9 | 51.1 | 35.9 | 41.7 | 47.9 | 52.1 |      |
|                     |     | SC   | 15.1 | 20.6 | 26.6 | 30.6 | 15.4 | 21.1 | 27.1 | 31.3 | 15.7 | 21.5 | 27.7 | 31.9 |      |
|                     |     | PI   | 6.52 | 6.55 | 6.58 | 6.62 | 6.58 | 6.62 | 6.65 | 6.68 | 6.65 | 6.68 | 6.72 | 6.75 |      |

Notes:

- All capacities are net and have considered indoor fan heat.
- TC=Total Capacity. (Unit:1000Btu/h)
- SC=SensibleCapacity. (Unit:1000Btu/h)
- different air volume in the above table, need to adjust in the field.

HEATING PERFORMANCE DATA—62HP(380V, 50Hz, 3Ph)

| Net Capacities(kW)-1850 CFM |  |      |      |      |  |      |      |      |
|-----------------------------|--|------|------|------|--|------|------|------|
| Outdoor Temp(°F) 70% RH     | Peak Net Heating(kW) at Indicated Dry Bulb(°F) |      |      |      | Peak Total Power(kW) at Indicated Dry Bulb(°F) |      |      |      |
|                             | 60   | 70   | 75   | 80   | 60   | 70   | 75   | 80   |
| 17                          | 34.5   | 33.8 | 33.5 | 33.2 | 4.19   | 4.45 | 4.58 | 4.71 |
| 22                          | 38.1   | 37.4 | 37.0 | 36.6 | 4.42   | 4.70 | 4.84 | 4.98 |
| 27                          | 41.7   | 40.9 | 40.5 | 40.1 | 4.66   | 4.95 | 5.10 | 5.25 |
| 32                          | 44.7   | 43.8 | 43.3 | 42.9 | 4.89   | 5.20 | 5.36 | 5.52 |
| 37                          | 49.6   | 48.6 | 48.1 | 47.6 | 5.19   | 5.52 | 5.68 | 5.85 |
| 42                          | 56.3   | 55.2 | 54.7 | 54.2 | 5.48   | 5.83 | 6.01 | 6.18 |
| 47                          | 63.6   | 62.5 | 61.9 | 61.4 | 5.78   | 6.15 | 6.33 | 6.51 |
| 52                          | 68.5   | 67.3 | 66.7 | 66.0 | 6.05   | 6.43 | 6.62 | 6.81 |
| 57                          | 73.4   | 72.1 | 71.4 | 70.7 | 6.31   | 6.71 | 6.91 | 7.11 |
| 62                          | 78.2   | 76.8 | 76.1 | 75.4 | 6.58   | 6.99 | 7.20 | 7.41 |
| 67                          | 83.1   | 81.6 | 80.9 | 80.1 | 6.84   | 7.28 | 7.49 | 7.71 |
| 72                          | 87.9   | 86.4 | 85.6 | 84.8 | 7.11   | 7.56 | 7.79 | 8.01 |

- For other airflows, see heating capacity correction factor tables.
- Heating capacities and power are integrated to include the effects of defrost in the frost region.

## 10. START-UP

### ■ PACKAGING AND COMPONENTS

- Is the unit properly located and level with the proper clearance?
- Is the duct work correctly sized, run, taped, insulated, and weatherproofed with proper unit arrangement? See Ductwork Installation section.
- Is the wiring properly sized and run according to the unit wiring diagram?
- Are all the wiring connections, including those in the unit, tight?
- Has the unit been properly grounded and fused with the recommended fuse size? See Wiring Data.
- Have the air conditioning systems been checked at the service ports for charge and leak tested if necessary?
- Does the condenser fan and indoor blower turn free without rubbing, and are they tight on the shafts?
- Has the indoor blower speed been determined and the proper speed been set? See the Unit Wiring Diagram.
- Are all covers and access panels in place to prevent air loss and safety hazards?

### ■ STARTING THE UNIT IN THE COOLING MODE

To start the unit in the cooling mode, set the thermostat system switch to COOL and move the thermostat COOL indicator to a setting below room temperature. The condenser (outdoor) fan motor compressor and evaporator (indoor) fan motor will operate automatically.

- Allow the heater to operate a minimum of eight (8) hours.



### CAUTION

Before starting the system on the cooling cycle, turn the thermostat switch to OFF and close the unit disconnect switch. This procedure energizes the compressor crankcase heater, vaporizing any liquid refrigerant in the crankcase. This is a precaution against foaming at startup which could damage the compressor bearings.

### ■ VOLTAGE

With the compressor operating, check the line voltage at the unit. The voltage should be within the range shown on the unit nameplate.

If low voltage is encountered, check the size and length of the supply line from the main disconnect to the unit. The line may be undersized for the length of the run.

### ■ COOLING SHUT DOWN

Place the system selector in the OFF position or reset thermostat at a setting above room temperature.

Do not de-energize the main power disconnect except when unit is to be serviced. Power is required to keep the heat pump compressor warm and boil off refrigerant in the compressor.

## 11. SYSTEM OPERATION

### ■ LED DISPLAY

The control would display any fault code that is currently active using the LED. The control will display the fault code, when the LEDS are flashing quickly, there is something wrong with the system. Refer to below table for detail fault code.

Function:

1. the compressor and indoor fan will start when the system is energized, outdoor fan starts with compressor.
2. When the system is de-energized, the outdoor fan and compressor would close soon, but the indoor fan would closed later.

### ■ Operational Codes:

| NUM | CODE  | LED1 (Red) | LED2 (Yellow) | LED3 (Green) |
|-----|---|------------|---------------|--------------|
| 1   | STANDBY                                     | OFF        | OFF           | ON           |
| 2   | FUNCTION                                    | ON         | ON            | ON           |
| 3   | PHASE-MISSING                               | FLASH      | FLASH         | FLASH        |
|     | PHASE-ERROR                                 |            |               |              |
| 4   | T1 SENSOR FAILURE                           | FLASH      | FLASH         | OFF          |
|     | HIGH PRESSURE PROTECTION                    |            |               |              |
|     | VENT PROTECTION                             |            |               |              |
| 5   | T2 SENSOR FAILURE                           | FLASH      | OFF           | FLASH        |
| 6   | T3 SENSOR FAILURE                           | OFF        | FLASH         | FLASH        |
| 7   | T4 SENSOR FAILURE                           | ON         | FLASH         | FLASH        |
| 8   | T2 EVAPORATOR LOW TEMP. PROTECTION          | OFF        | FLASH         | OFF          |
| 9   | T2 EVAPORATOR HIGH TEMP. PROTECTION         | FLASH      | ON            | ON           |
| 10  | T3 CONDENSOR HIGH TEMP. PROTECTION          | FLASH      | OFF           | OFF          |
| 11  | WIRED CONTROLLER INPUT FAILURE              | FLASH      | FLASH         | ON           |
| 12  | COMPRESSOR OVERCURRENT PROTECTION           | OFF        | OFF           | FLASH        |
| 13  | COMPRESSOR-INHALING LOW PRESSURE PROTECTION | FLASH      | ON            | FLASH        |
| 14  | DEFROST                                     | ON         | FLASH         | ON           |

### ■ Low pressure switch

The control will detect the status of low pressure switch, which is normally close. If the low pressure switch is open during the first time of power supply, the control will de-energized the compressor. If low pressure switch protection appears 3 times in 20 minutes, the control should be restored by switch off the power supply. The control will ignore the low pressure switch input during the following conditions: defrost operation, 4 minutes following the completion of a defrost cycle, first 5 minute of compressor operation during the heat mode.

### ■ HIGH-PRESSURE SWITCH

The Unit is equipped with a high-pressure switch that is connected to the main board, If the high-pressure switch opens for more than 40 milliseconds, the control will de-energize the compressor and store and display the appropriate fault code. If the pressure switch closes and a thermostat call for compressor operation is present, the control will apply the three-minute anti-short cycle delay timer and start the compressor when the timer expires.

### ■ TEMPERATURE SENSOR

The unit have two temperature sensors, which are called T3 and T4, T3 means pipe temperature sensor, T4 means outdoor unit circumstance temperature sensor. When the temperature sensor was damaged, the system would closed and the LED would flashing.

### ■ INDICATIONS OF PROPER OPERATION

when the LEDS in a lighting states, no matter which one, it is means the system runs properly.



## 12. MAINTENANCE

### ■ ROUTINE MAINTENANCE BY OWNER

You can do some of the periodic maintenance functions for your unit yourself; this includes cleaning the permanent air filters, cleaning the unit cabinet, cleaning the condenser coil, and conducting a general unit inspection on a regular basis.

### ■ CLEANING THE AIR FILTER

1. Dismantle the air filter.
  - Twist of screws, then the filter baffle gets out.
  - Drag out filter.

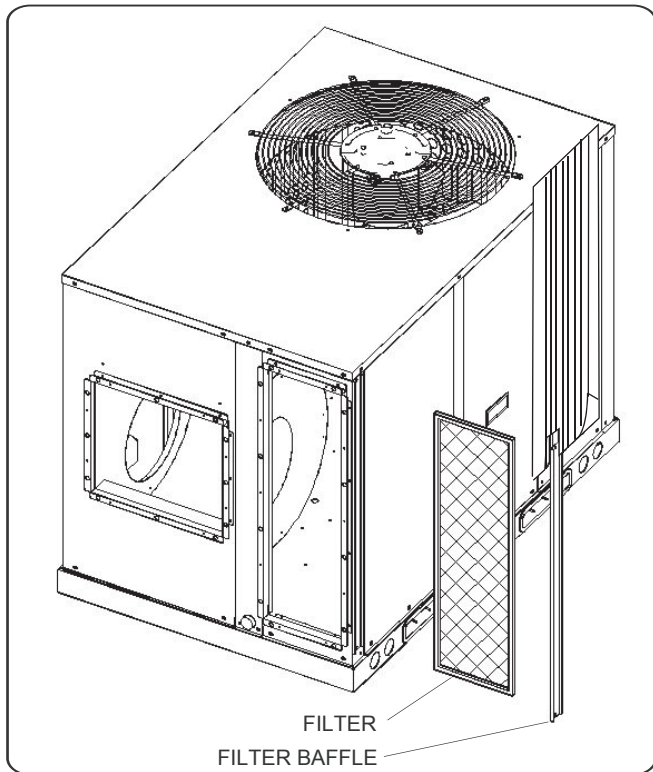

Figure 9

2. Clean the air filter (Vacuum cleaner or pure water may be used to clean the air filter. If the dust accumulation is too heavy, please use soft brush and mild detergent to clean it and dry out.)

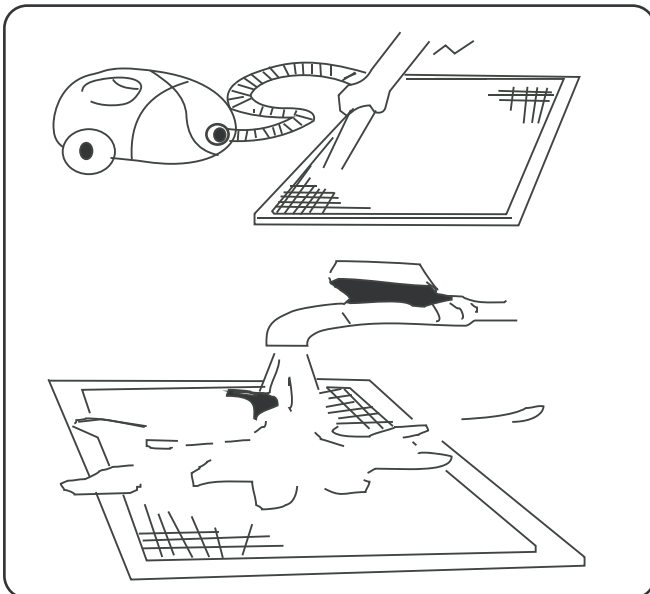

Figure 10

- The air-in side should face up when using vacuum cleaner.
- The air-in side should face down when using water.



### CAUTION

Do not dry out the air filter under direct sunshine or with fire.

3. Re-install the air filter

### ■ CONDENSER COIL

Unfiltered air circulates through the unit's condenser coil and can cause the coil's surface to become clogged with dust, dirt, etc. To clean the coil, vertically (i.e., with the fins) stroke the coil surface with a soft-bristled brush. Be sure to keep all vegetation away from the condenser coil area.

### ■ MAINTENANCE PERFORMED BY SERVICEMAN-COOLING SEASON

To keep your unit operating safely and efficiently, the manufacturer recommends that a qualified serviceman check the entire system at least once each year and any other time that you feel one is needed. Your serviceman should examine these areas of your unit:

- Filters
- Motors and drive system components
- Economizer gaskets (for possible replacement)
- Safety controls (for mechanical cleaning)
- Electrical components and wiring (for possible replacement and connection tightness)
- Condensate drain (for cleaning)
- Unit duct connections (to see that they are physically sound and sealed to the unit casing)
- Unit mounting support (for structural integrity)
- The unit (for obvious unit deterioration)



### CAUTION

Do not operate the unit without the evaporator fan access panel in place. reinstall the access panel after performing any maintenance procedures on the fan. operating the unit without the access panel properly installed may result in severe personal injury or death.