



Installation, Startup and Maintenance Manual
Original Instructions

A Series Inverter Modular Air-cooled Chiller (Heat Pump)

CWCH4IN-35KT, CWCH4IN-60KT, CWCH4IN-65KT, CWCH4IN-70KT

To Users

Thank you for selecting Cardiff product. Please read this instruction manual carefully before installing and using the product, so as to master and correctly use the product. In order to guide you to correctly install and use our product and achieve expected operating effect, we hereby instruct as below:





- (1) This appliance can be used by children aged from 8 years and above and persons with reduced physical, sensory or mental capabilities or lack of experience and knowledge if they have been given supervision or instruction concerning use of the appliance in a safe way and understand the hazards involved. Children shall not play with the appliance. Cleaning and user maintenance shall not be made by children without supervision.
- (2) This product has gone through strict inspection and operational test before leaving the factory. In order to avoid damage due to improper disassembly and inspection, which may impact the normal operation of unit, please do not disassemble the unit by yourself. You can contact with the special maintenance center of our company if necessary.
- (3) For personal injury or property loss and damage caused by improper operation such as improper installation and debugging, unnecessary maintenance, violation of related national laws and rules and industrial standard, and violation of this instruction manual, etc., we will bear no liability.
- (4) When the product is faulted and cannot be operated, please contact with our maintenance center as soon as possible by providing the following information.
 - 1) Contents of nameplate of product (model, cooling/heating capacity, product No., ex-factory date).
 - 2) Malfunction status (specify the situations before and after the error occurs).
- (5) All the illustrations and information in the instruction manual are only for reference. In order to make the product better, we will continuously conduct improvement and innovation. We have the right to make necessary revision to the product from time to time due to the reason of sales or production, and reserve the right to revise the contents without further notice.
- (6) The final right to interpret for this instruction manual belongs to Cardiff

Contents

1 Safety Notices.....	1
2 General Introduction.....	7
2.1 Product Features.....	7
2.2 Principle Diagrams.....	8
3 Operation Range.....	8
4 Outline Dimensions.....	9
5 Installation Instructions.....	10
5.1 Pre-check.....	10
5.2 Acceptance Check.....	10
5.3 Handling and Lifting.....	11
5.4 Installation Foundation and Service Space.....	12
5.5 Vibration Reduction.....	13
5.6 Installation of the Water System.....	14
6 Introduction to the Display Panel.....	16
7 Electric Wiring.....	16
7.1 External Wiring of the Electric Control Cabinet.....	16
7.2 Specification of Power Cord and Air Switch.....	17
7.3 Wiring of the Electric Control Cabinet.....	18
7.4 Filed Wiring.....	18
7.5 Networking and Wiring between Units.....	20
7.6 Setup of Toggle Switches on the Motherboard.....	21
7.7 Jumpers.....	22
8 Commissioning and Maintenance.....	23
8.1 Check before Startup.....	23
8.2 Requirements on Water Quality and Cleaning.....	23
8.3 Trial Run.....	25
8.4 Routine Startup/Shutdown.....	25
8.5 Maintenance to the Main Parts.....	26
8.6 Maintenance during Long-term Downtime.....	26
8.7 Startup after Long-term Shutdown.....	26
8.8 Parts Replacement.....	26
8.9 Refrigerant Charging.....	27
8.10 Removal of the Compressor.....	27
8.11 Freeze Protection.....	28

8.12 Rountine Maintenance.....	28
8.13 Precautions.....	29
9 Troubleshooting and After-sales Service	30
9.1 Troubleshooting Measures	30
9.2 After-sales Service	32

1 Safety Notices

	Warning: If not abided strictly, it may cause severe damage to the unit or the people.
	Note: If not abided strictly, it may cause slight or medium damage to the unit or the people.
	This sign indicates that the operation must be prohibited. Improper operation may cause severe damage or death to people.
	This sign indicates that the items must be observed. Improper operation may cause damage to people or property.

◆ Safety Notices for On-site Installation

WARNING

- (1) Installation should be performed by qualified servicemen who have taken specialized training and acquired corresponding certificates in accordance with relative laws, regulations and this manual, otherwise it would lead to damage to the unit, water leakage, electrocution, or fire hazards etc.
- (2) The unit should be installed on the smooth foundation capable of supporting the unit and fixed with screw bolts. The foundation with inadequate strength would lead to leakage, turn-over or personal injury or death.
- (3) Special lines should be used for electric installation by qualified electricians. Lines with inadequate capacity would lead to electrocution or fire hazards.
- (4) Make sure each connector is properly tightened; otherwise it would lead to overtemperature or fire hazards etc.
- (5) When installation is finished, please check for the drainage lines, pipelines, and electric lines to prevent water leakage, electrocution or fire hazards.
- (6) The appliance is intended to be permanently connected to the water mains and not connected by a hose-set.
- (7) This equipment should be installed where the drainage system can work well. Never block the drain hole. Improper drainage system would lead to drainage difficulty and make the unit suffer from malfunctions.
- (8) When there is something unusual (like stinky smell) during installation or commissioning, please cut off the main power at once and then contact the aftersales service center. This ongoing unusual condition will damage the air conditioning unit and lead to electrocution or fire hazards
- (9) When refrigerant leaks, take corrective measures as soon as possible to prevent oxygen depletion by increased refrigerant concentration.

⚠ NOTE

- (1) Do not install the unit where there is high-intensity magnetic field or it is highly basic or acid or the voltage is quietly unstable.
- (2) Do not install the unit where there would be leaked inflammable gas, as it would lead to fire hazards.
- (3) The outer casing of the unit should be grounded. Do not connect the grounding line to the gas line, water line, lightning rod or communication line, otherwise it would lead to electric shocks.
- (4) The appliance shall be installed in accordance with national wiring regulations, the appliance shall be disconnected from its power source during service and when replacing parts.
- (5) Do not stand on the unit or place other object on it.
- (6) Do not insert fingers or other objects into the outlet grill to prevent damage to the unit or personal injury or death.
- (7) Do not start or stop the unit by inserting or drawing out the power plug.
- (8) Do not let children play with this unit.
- (9) The unit should be equipped with the leakage protector which should be installed in accordance with electric technical standards. Uninstallation or incorrect installation would lead to electrocution. Do electric leakage detection after electric installation is finished.
- (10) Volatile liquid like thinner or gasoline would damage appearance of the unit. (Only clean the outer casing with of the unit with soft dry cloth or wet cloth with neutral detergent.

⚠ DANGER

- (1) Do not install the unit where conditions are severe, where it is close to the hot spring, coast or oil field, as it would lead to corrosion, electrocution or fire hazards. Besides, do not install the unit where there are corrosive, inflammable substances or smog, otherwise it would lead to normal operation failure, shortened service life, fire hazard, or severe injury.
- (2) Do not start the compressor by manually closing the AC contactor, otherwise it would lead to electrocution or fire hazard.
- (3) Do not misuse refrigerant, as it would lead to normal operation failure, unsatisfactory performance, fire hazards or even explosion etc.

ⓘ CAUTION

- (1) Installation should be done in accordance with this manual. Please read it manually prior to startup or troubleshooting.
- (2) Installation should be done by qualified servicemen, as incorrect installation would lead to water leakage, electrocution or fire hazards etc.
- (3) Before installation, check for all power supplies with the nameplate and check for its safety.
- (4) The unit should be grounded and there should be specialized grounding line for the power socket to avoid of electrocution. Do not connect the grounding line to the gas tank, water line, lightning rod, or telephone line.
- (5) Only specialized accessories and parts are allowed for installation, otherwise it would lead to water leakage, electrocution or fire hazards etc.
- (6) Size of the power lines should be large enough. Only specialized power lines are allowed for replacing the damaged ones.
- (7) When power lines have been connected, install the electric box as well to avoid of any safety problems.
- (8) After all installation has been finished, take an overall check to the unit before powering it on.

◆ Safety Precautions for Usage and Maintenance

⚠ WARNING

- (1) When there is something unusual (like burnt smell), cut off the power supply at once and contact the sales agent. The ongoing unusual condition would lead to malfunctions, electrocution or fire hazards.
- (2) When refrigerant leaks, take corrective measures to prevent oxygen depletion by increasing refrigerant concentration.
- (3) Do not use or place inflammable or explosive substances near the unit.
- (4) Do not do troubleshooting personally, as incorrect troubleshooting would lead to electrocution or fire hazards. Instead, please contact CARDIFF after-sales service center.
- (5) When the unit is charged with refrigerant, do not solder or cut any pipeline, fined heat exchanger, shell-and-tube heat exchanger or other containers.

△ NOTE

- (1) Do not let the unit out of the designed application range; otherwise it would cause the heat exchanging tube cracking, refrigerant leakage or even explosion.
- (2) Do not let the cold/heat source directly act on the stored foods, plants, animals, precision instruments, and curiosities, otherwise their quality would be degraded.
- (3) Only circulating water with satisfactory water quality are allowed for the unit, as unsatisfactory water quality would shorten the service life of the unit or even malfunctions.
- (4) When the unit has been put into use for some time, check for security of the installation foundation. Unstable foundation would lead to deformation or even safety accident.
- (5) Once the unit is started up, stop it at least 6 minutes later, otherwise it would shorten the service life of the unit. Never deliberately start or stop the unit frequently.
- (6) Under subzero climatic conditions, pay attention to freeze protection. When the unit is out of use in short time, do not cut off the power supply, as freeze protection will not act normally. When the unit is out of used in quite long time, add anti-freezing agent to water or drain the water system, otherwise it would make the shell and tube crack and then leak.

⊘ DANGER

- (1) Do not use the fuse out of the normal range or replace it with the electric wire, otherwise it would damage the unit or lead to fire hazards.
- (2) Do not start or stop the unit directly by the power switch, as it would be likely to cause electrocution or fire hazards.
- (3) Do not change settings of safety devices; otherwise it would lead to fire hazards and explosion.
- (4) Do not operate the unit with wet hands.
- (5) Do not clean the unit without cutting off the power supply, as it would lead to electrocution or personal injury.
- (6) Do not let children pull power lines or climb the unit to prevent of electrocution or other dangers.
- (7) Do not touch high-temperature parts of the compressor and refrigerant lines, as it would lead to burns.
- (8) Do not touch sharp edges and fins of the heat exchanger; otherwise it would lead to personal injury.
- (9) Do not touch any moving part; otherwise it would lead to accidental injury.
- (10) Do not stand on the unit or place objects on it.
- (11) Do not bend pipeline and retrofit the unit, otherwise it would lead to refrigerant leakage, explosion, fire hazards or personal injury.

ⓘ CAUTION

- (1) Do not operate the unit in accordance with this manual and read it carefully before startup or troubleshooting.
- (2) Do not turn on or off the unit with the controller.

◆ Safety Precaution for Handling of the Unit

Safety Precaution for Handling of the Unit

⚠ WARNING

- (1) Please contact the contractor for handling and installation. Improper installation would lead to electrocution or fire hazard.
- (2) During installation or handling, do not let foreign matters mixed with refrigerant and do not let air trapped inside the pipe, as it would lead to increased system pressure or explosion of the compressor.
- (3) Only specialized power lines are allowed. Wiring terminals should suffer no any external force and are fixed properly; otherwise it would lead to fire hazards. Besides, make sure insulation of power lines always in good condition.
- (4) Connection between two ends of the power lines is not allowed. When its length is not enough, please contact the after-sales service center for customizing another one long enough.

⚠ CAUTION

- (1) Treatment of water, cleaning solution, refrigerant or other waste liquid or gas should comply with local laws and regulations; otherwise it would lead to adverse effect to health and environment.
- (2) Do not misuse refrigerant, as it is one of the causes of fire hazard and explosion.

Precautions for Refrigerant Charging

⚠ NOTE

When charging is interrupted or finished, reinspect the unit but do not let the compressor run into operation.

⚠ WARNING

Do not use mixture of refrigerant vapor and air or oxygen for pressurizing for fear of explosion.

Correct Disposal

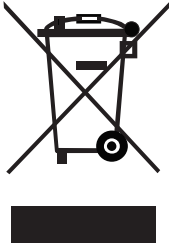

This marking indicates that this product should not be disposed with other household wastes throughout the EU. To prevent possible harm to the environment or human health from uncontrolled waste disposal, recycle it responsibly to promote the sustainable reuse of material resources. To return your used device, please use the return and collection systems or contact the retailer where the product was purchased. They can take this product for environmental safe recycling.

2 General Introduction

See the nameplate for the main technical data.

The all-inverter modular air-cooled chillers are capable of performing cooling all year around with high energy efficient. It requires no cooling towers and is quite applicable to water-deficient areas, and can be widely used at newly built or retrofitted industrial and civil buildings in various sizes, such as, hotels, apartments, restaurants, office buildings, shopping malls, theaters, gyms, workshops, hospitals, places where there is requirement on cooling under ultra-low temperature, like cold storages, places where require cooling for dairy products, foods and industrial products, and especially places where there are high requirements on noise level and surrounding environment and boils and cooling towers are not allowed or hard to be installed.

2. 1 Product Features

The all-inverter modular air-cooled chillers work outstandingly by virtue of their major features stated below..

- **Excellent compatibility :**

The all-inverter modular air-cooled chillers can be constructed of multiple single units with the same or different structure or capability (35kW, 60kW, 65kW and 70kW). For the 35kW unit, it has only one cooling system; for the 60kW, 65kW and 70kW units, they are of two independent systems. Up to 16 single units can be modularized, with cooling capacity ranging from 35kW to 1104kW.

- **Comfort and energy saving :**

The variable-frequency technology can quickly respond to load change and lead to decreased water temperature fluctuation and better comfort.

- **Ultra-quiet :**

The high-efficiency and low-noise fan blades and motor as well as the optimized air passage can greatly lower operation noise of the unit. Besides, the quiet mode can provide the user a ultra-quiet environment.

- **Powerful self-protection :**

It is equipped with the top-end microcomputer control system which is capable of providing well-rounded protection and self-diagnosis.

- **High reliability :**

It is constructed of well-designed refrigeration parts and well-designed system, structure and electric control, adequately guaranteeing reliable operation

- **Remote ON/OFF :**

The unit can be started or stopped by the ON/OFF key operation.

- **Equilibrium running :**

It indicates each compressor will run alternately so as to extend their service life.

- **Shiftwork of water pumps :**

Two water pumps can work alternately with equilibrium runtime so as to extend their service life and lower the maintenance difficulty.

2. 2 Principle Diagrams

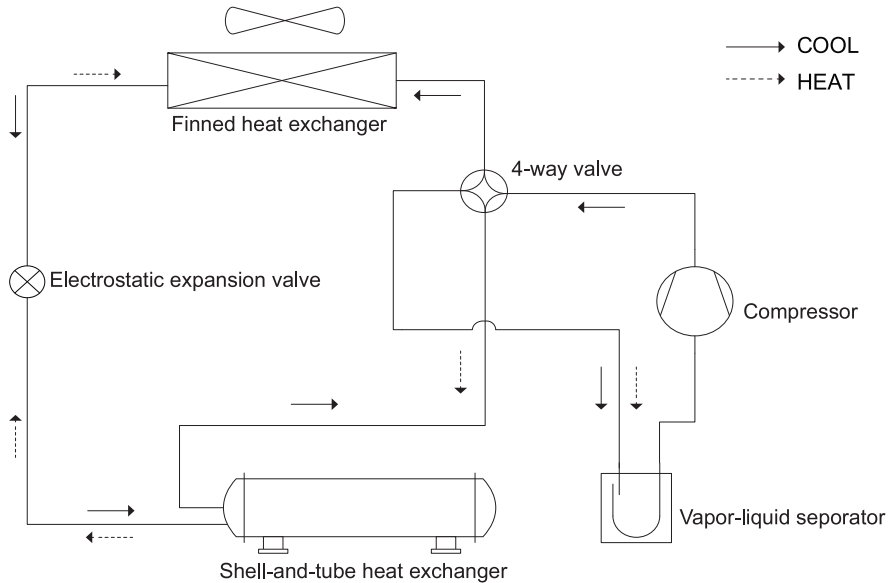

3 Operation Range

Please run the unit under the specified operation range as shown in the table below:

■ R410A Series

Item	Water Side		Air Side
	Leaving Water Temperature (°C)	Water Temperature Difference (°C)	Ambient DB Temperature (°C)
Cooling	5 ~ 20	2.5 ~ 6	-15 ~ 52
Heating	35 ~ 50	2.5 ~ 6	-20 ~ 40

maximum and minimum entering water pressures:

Item	Minimum entering water pressures	Maximum entering water pressures
Cooling	0.06MPa	1.6MPa
Heating		

4 Outline Dimensions

(1) CWCH4IN-35KT(unit:mm)

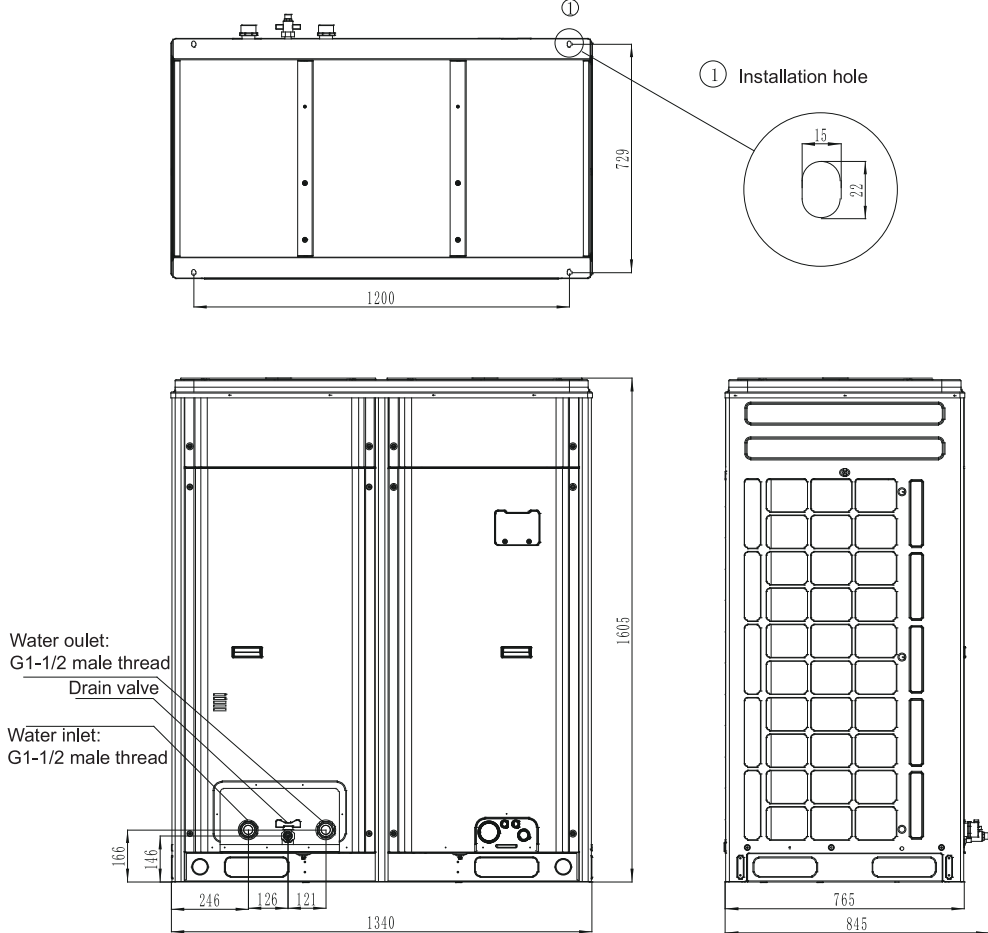

(2) CWCH4IN-60KT, CWCH4IN-65KT, CWCH4IN-70KT (unit:mm)

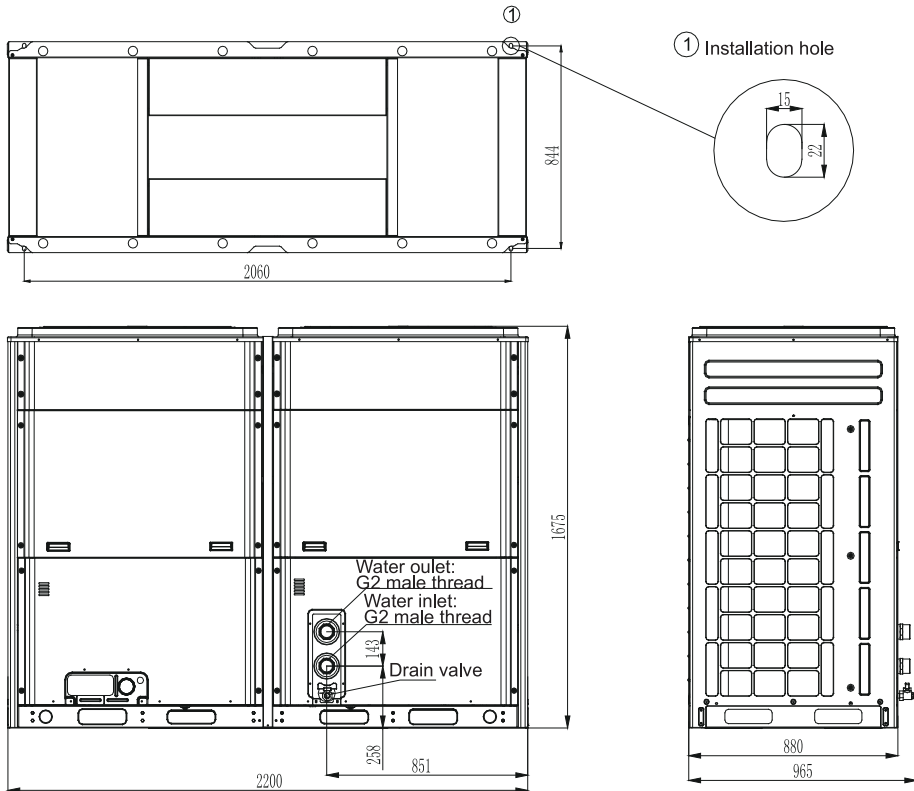

5 Installation Instructions

5.1 Pre-check

Installation should be performed by the skilled technician to guarantee the normal operation and prevent malfunctions and please read this manual carefully prior to installation.

The chiller is manufactured, inspected and tested strictly in accordance with the quality control program and it will work properly within the expected service life as long as its installation, operation and service.

5.2 Acceptance Check

The user is responsible for organizing personnel to perform the acceptance check at the regulated plate of delivery. Checks listed below should be taken as a minimum.

- (1) If all required documents and accessories are provided as per the packing list.
- (2) Check the equipment model.
- (3) If the equipment is damaged and all parts are provided.
- (4) If refrigerant leaks.
- (5) Do not remove the protective cover on the flagon of the shell-and-tube heat exchanger before connecting the water tube and check if the water pipe is clean.
- (6) Check if the installation and operation are within the allowable conditions.

When there is damage or any other question, contact the local sales representative for applicable solutions.

△ NOTE

After the acceptance check, take necessary protection to the unpacked equipment. Note that it is not recommended to unpack the equipment too early to avoid any unexpected damage.

5. 3 Handling and Lifting

Each unit will undergo a series of strict factory inspections and tests to guarantee the expected performance and quality. However, special attention should be paid during handling and shipping to prevent the control system and the piping system from being damaged.

The unit should be moved by the forklift or hoisting machine. During lifting, the canvas lifting or steel ropes in use should be of enough strength and go through the based and then bundled tightly. The unit should be lifted stably from four corners. Meanwhile, be sure there should be protective pads to prevent lifting ropes contacting with the unit. The inclination angle during lifting should be less than 15 degree. The unit should be moved softly and severe collision and forced drag are not allowed. Please do lifting as shown in the figure below for units with similar structure.

During hoisting, the length of the spreader should be longer than that of the unit.

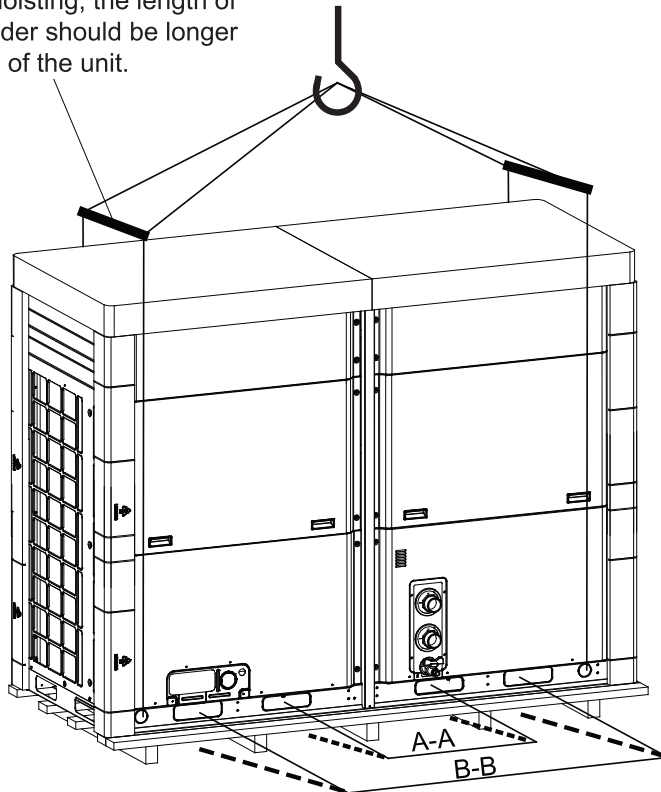

During transport by the forklift, the symmetric holes should be used at the A-A or B-B base of the unit itself, or at the wooden base.

5. 4 Installation Foundation and Service Space

- (1) Installation foundation shall be designed by the qualified designer in accordance with the actual condition.
- (2) A rubber pad shall be placed under the base of each single unit and then secured on the ground or the roof. Alternatively, each single unit can be placed side by side on the parallel channel steel with enough strength which then shall be secured with anchor bolts. Distance between each single unit shall be keep 0.5m as a minimal.
- (3) Enough space shall be left for service and ventilation. There should be good ventilation around the unit. Beside, be sure there is at least 1m between the unit and any barrier, and at least 1.2m should be kept at the side of the water inlet and outlet pipes. If possible, it is better to set up a sun cover 3m ahead of the unit.
- (4) The unit shall be installed where it will not be affected by fire, corrosive, inflammable or waste gas, and proper measures shall be taken to minimize the vibration and noise.
- (5) The unit shall be installed where the defrosting water can be drained out favorably
- (6) Do not install the unit where there is heavy snow. If inevitable, build a foundation at least 300mm higher than the ground.

■ Installation Space for the Single Unit

(Unit : mm)

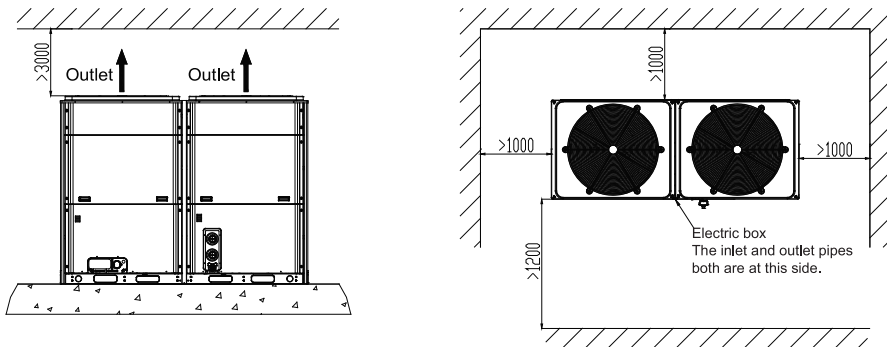

■ Installation Space for Modularized Units

(Unit : mm)

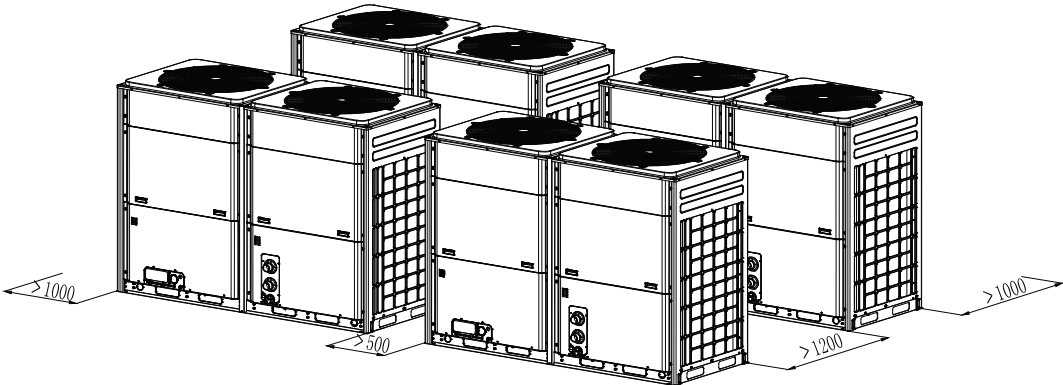
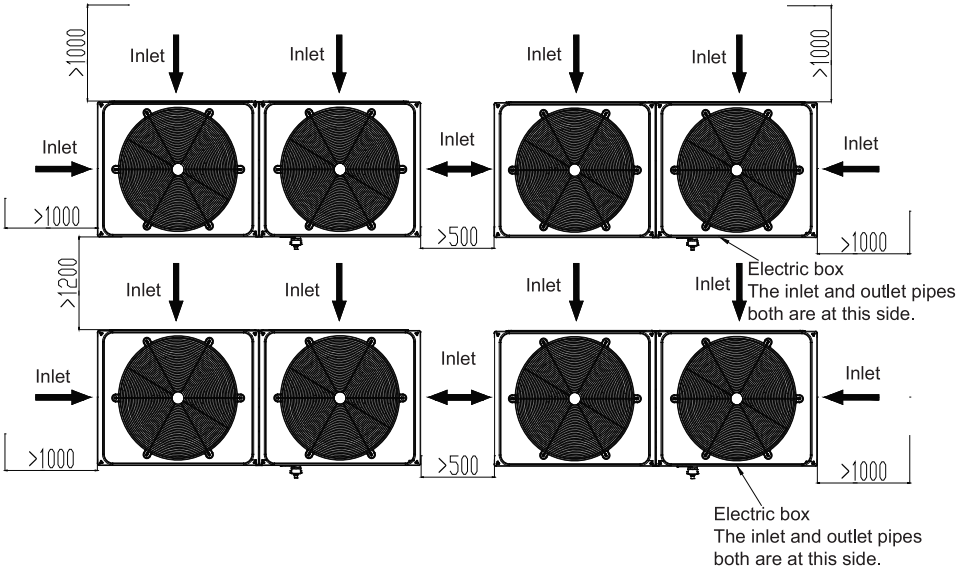
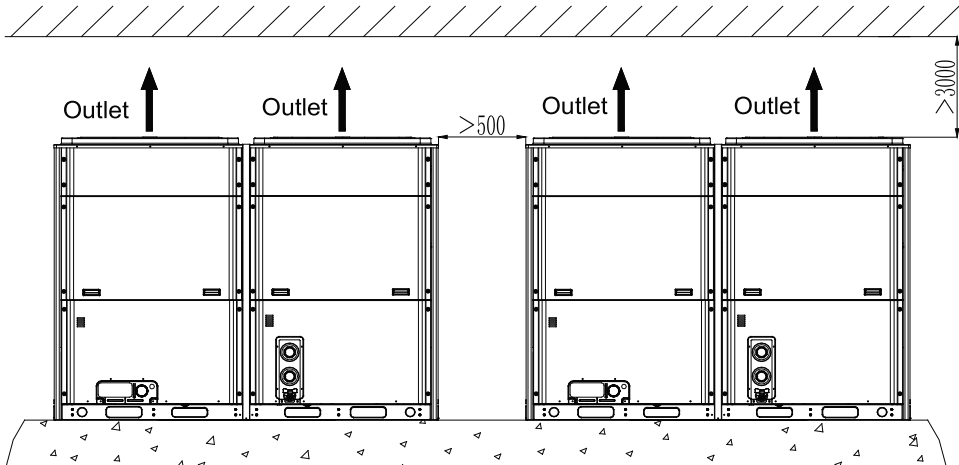

Note: diagrams above are just for reference and not in real proportion.

5. 5 Vibration Reduction

The unit shall be securely attached to the foundation through the mounting hole by following the steps below.

- (1) Be sure the planeness of the concrete foundation is within $\pm 3\text{mm}$ and the foundation shall be covered by a rubber pad.
- (2) Lift the unit until to the height where it is available to install the spring shock absorber.
- (3) Remove screws fixing the spring shock absorber.
- (4) Place the unit on the spring shock absorber and align the bolt holes of the spring shock absorber with the mounting holes on the base of the unit.
- (5) Tighten screws removed in step 2.
- (6) Adjust the height of the spring shock absorber and make sure the deflection is equal all round the spring shock absorber.
- (7) Tighten the locking screws.

5.6 Installation of the Water System

- Considerations stated below shall be taken carefully for the water system.
- (1) Each water inlet and outlet should be labeled properly to avoid misconnection.
 - (2) A flexible connector should be used at the chilled water outlet to reduce vibration transmission.
 - (3) A manometer, a thermometer and a gate valve shall be installed at the chilled water inlet /outlet. Moreover, a drain valve shall be installed at the outlet and an air release valve shall be installed at the inlet. At the highest point of the water system, another release valve shall be installed, while at the lowest point of the water system, another drain valve shall be installed to facilitate drainage.
 - (4) The water inlet/outlet pipe should be tightly insulated to reduce heat loss and dewing. When pipes are exposed under 0°C , a electric heater shall be installed.
 - (5) There surely be some foreign matters in the water system which would generate scale on the surface of the heat exchanger, so a filter shall be installed upstream of the water pump.
 - (6) The unit shall be bypassed during flushing to prevent drain out from entering the system.
 - (7) Under ultra-low temperature in winter, shutdown at night will cause the evaporator and pipeline frozen up, so it is highly recommended to add alcohol and propanol mixture in chilled water. Do not cut off the power supply when the unit is turned off, otherwise the freeze protection does not work. Alternatively, cut off the power supply and drain the water system thoroughly.
 - (8) When the unit runs under the low load requirement, in order to avoid low load protection which would affect the service life of the unit, make sure the water capacity is more than $1/6$ of total rated flow rate per hour of each module (for instance, for some project with four modularized CWCH4IN-60KT units, if the rated water flow of each unit is $10.3\text{m}^3/\text{h}$, then the required capacity of the whole project should be larger than $10.3 \times 4 \times 1/6 = 6.87\text{m}^3/\text{h}$). When the water course is quite short, a water tank is required; otherwise the service life of the unit would be affected.

NOTE

Never use salt mixture to prevent the unit from being corroded.

■ How to install the water system

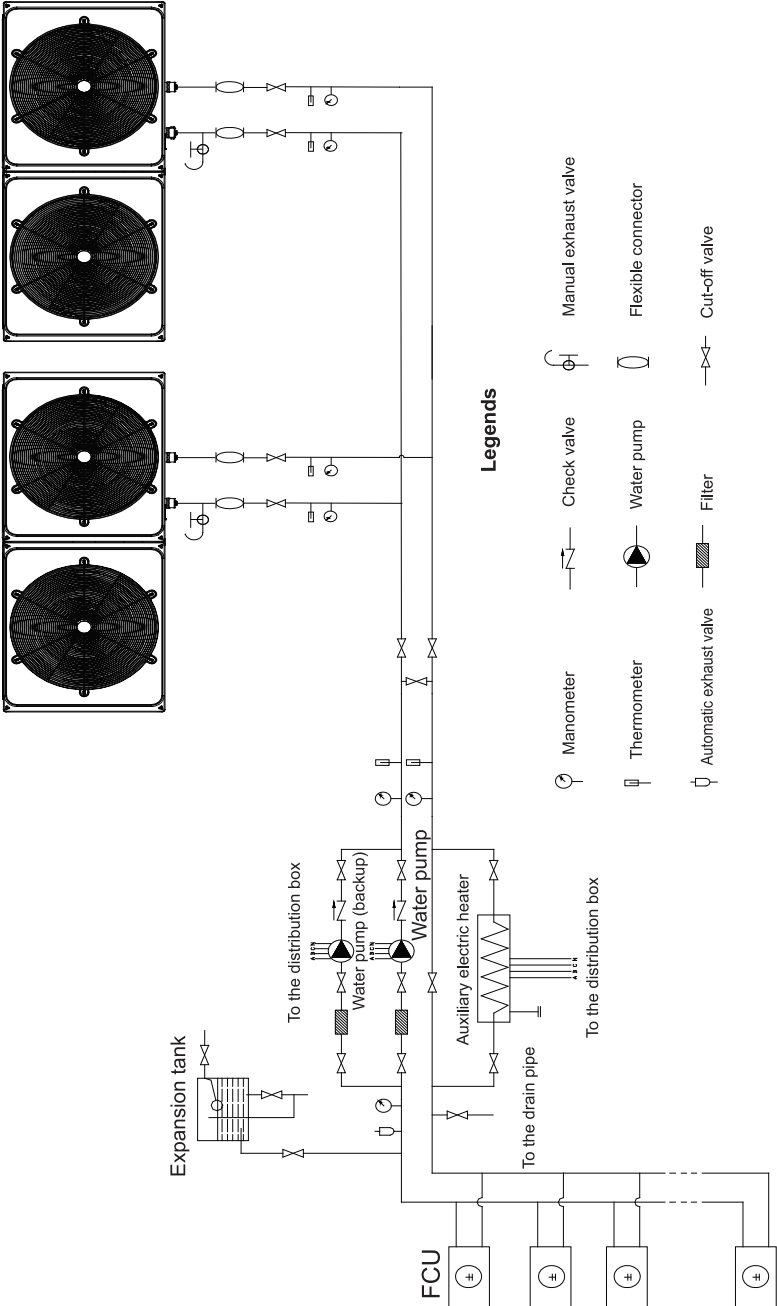

■ How to drain the water system :

(1) Loosen screws around the panel and then take down it.

- (2) Remove anticlockwise the blind plug located at the bottom of the heat exchanger to let the chilled water flow out, after that, tighten the blind plug and reinstall the panel. (-
 Note: place the drainage equipment beneath the drain pipe to prevent pollution caused by the drain water.

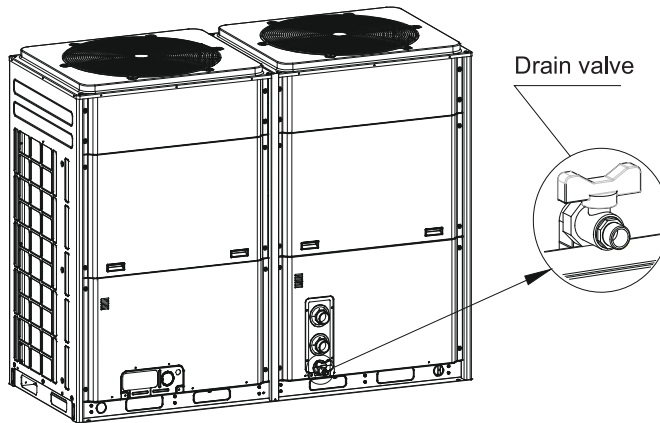

NOTE

Keep the purge valve of the water system open in order to drain the evaporator and condenser completely.

6 Introduction to the Display Panel

See the Operation Instructions for the Display Panel of the inverter modular type chillers for more details.

7 Electric Wiring

7. 1 External Wiring of the Electric Control Cabinet

- CWCH4IN-35KT, CWCH4IN-60KT, CWCH4IN-65KT, CWCH4IN-70KT

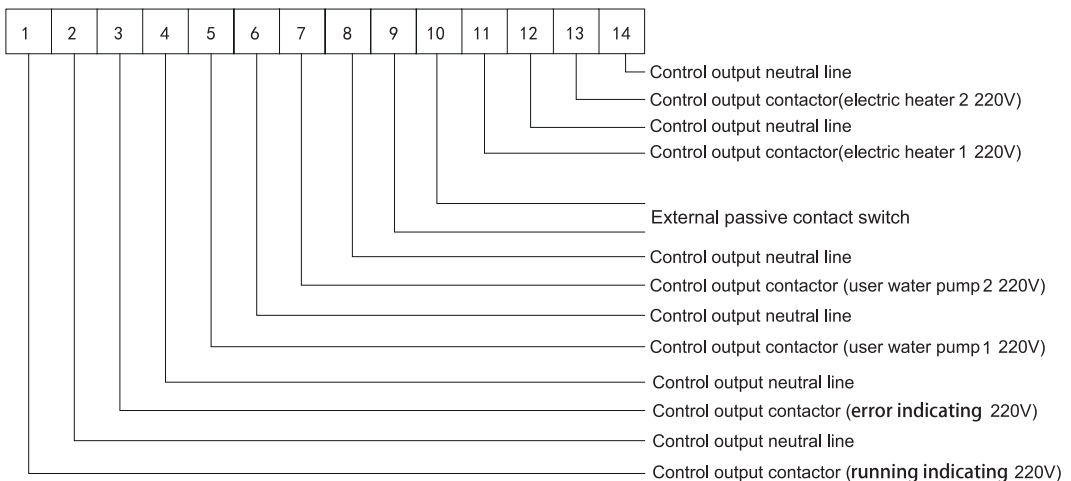

Note: the output control lines of the AC contactors for the running indicator, water pump 1, water pump 2, auxiliary electric heater 1, auxiliary electric heater 2 can be wired to the

corresponding wiring board of any one unit, while those for the error indicator and external passive contact switch should be wired to the corresponding wiring board of all units as shown in the figure below.

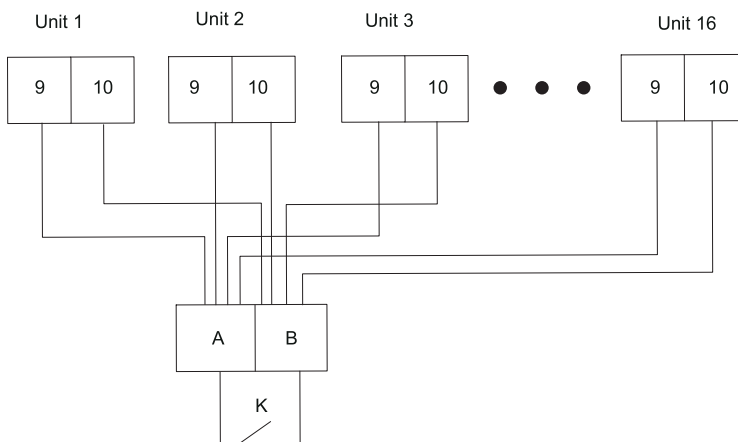

When external passive contact switch is available for multiple units, the wiring board 9 and 10 of each unit should be wired to the dry contact A and B.

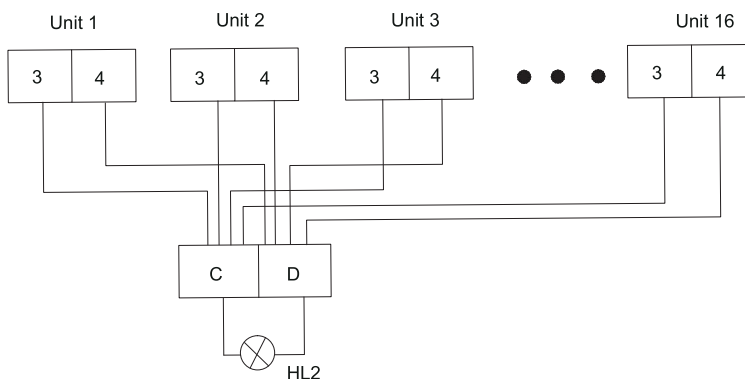

When it is required to display errors of several units, the wiring terminals (3, 4) of each unit should be wired to the wiring terminals HL2 (C, D) of the error indicator. (If it is required to display the error of each unit independently, then the error indicator of each unit should be wired independently to the corresponding error output wiring terminals (3,4) of each unit.)

7. 2 Specification of Power Cord and Air Switch

See the table below for selectin of the power lines and the air switches.

Model	Power Supply	Min. sectional area of the power cable (mm ²)			Capability of the Air Switch Live (A)
		Live Line	Neutral Line	Earth Line	
CWCH4IN-35KT	380V ~ 415VAC 3Ph 50Hz	6	6	6	32
CWCH4IN-60KT	380V ~ 415VAC 3Ph 50Hz	16	16	16	63

CWCH4IN-65KT	380V ~ 415VAC 3Ph 50Hz	16	16	16	63
CWCH4IN-70KT	380V ~ 415VAC 3Ph 50Hz	16	16	16	63

Notes:

- (1)The specifications of the breaker and power cable listed in the table above are determined based on the maximum power (maximum amps) of the unit.
- (2)The specifications of the power cable listed in the table above are applied to the conduit-guarded multi-wire copper cable (like, JYV copper cable, consisting of PV insulated wires and a PVC cable jacket) used at 45°C and resistible to 90°C(GB/T 16895.15-2002). If the working condition changes, they should be modified according to the related national standard.
- (3)The specifications of the breaker listed in the table above are applied to the breaker with the working temperature at 40°C. If the working condition changes, they should be modified according to the related national standard.

7. 3 Wiring of the Electric Control Cabinet

- CWCH4IN-35KT, CWCH4IN-60KT, CWCH4IN-65KT, CWCH4IN-70KT

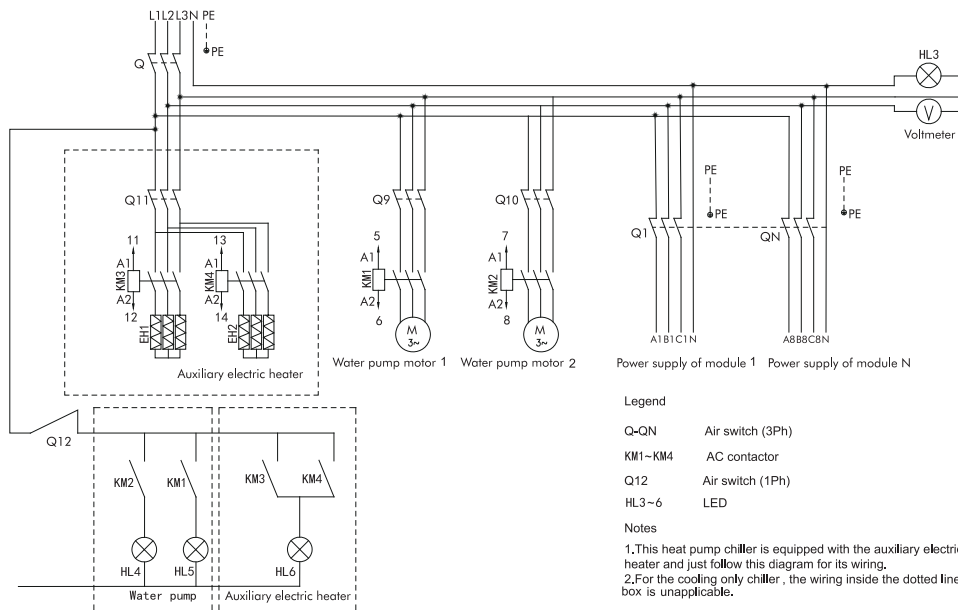

7. 4 Field Wiring

- Safety Codes

- (1)All wiring shall comply with applicable codes and engineering requirements.
- (2)All field wiring shall be performed by the qualified electrician.
- (3)Never perform wiring before the power supply is cut off.

(4)Any damage caused by the improper external wiring shall be at the installer's expense.

△WARNING

Only copper conductor is allowed.

■ How to wire the power lines to the electric box

- (1)The power cord must be routed inside the conduit.
- (2)The power cord must enter the electric box through a rubber or plastic ring to avoid any damaged caused by the sharp edge of the metal sheet.
- (3)The power cord close to the electric box must be attached securely to prevent the terminal block of the electric box affected by the outside force. The Power cord shall be installed with a suitable cord anchorage against cord loosening.
- (4)The unit shall be grounded reliably and never connect the ground wire with the gas fuel pipe, water pipe, lightening rod or telephone line.
- (5)After wiring, O-rings should be tightened to prevent coming of insects.

■ Control Line

- (1)The field supplied control line shall be at a minimum 1mm².
- (2)The electric box will send the control signal (220 AC, 5A) to control the chilled water pump and auxiliary electric heater, however, never do not drive them directly through the control signal but through their AC contactors.
- (3)Switching signals (220VAC, 2A) for the running and error indicators are available for the electric box.
- (4)The remote switch control signal is available for the electric box and please pay attention to the input passive dry contact.
- (5)A reasonable length of the control line should be left outside the unit and the rest should be bundled and fed into the electric box.
- (6)The connection line of the display panel and main board is reliably grounded through the main board. Beside, communication lines between units also should be grounded.

7. 5 Networking and Wiring between Units

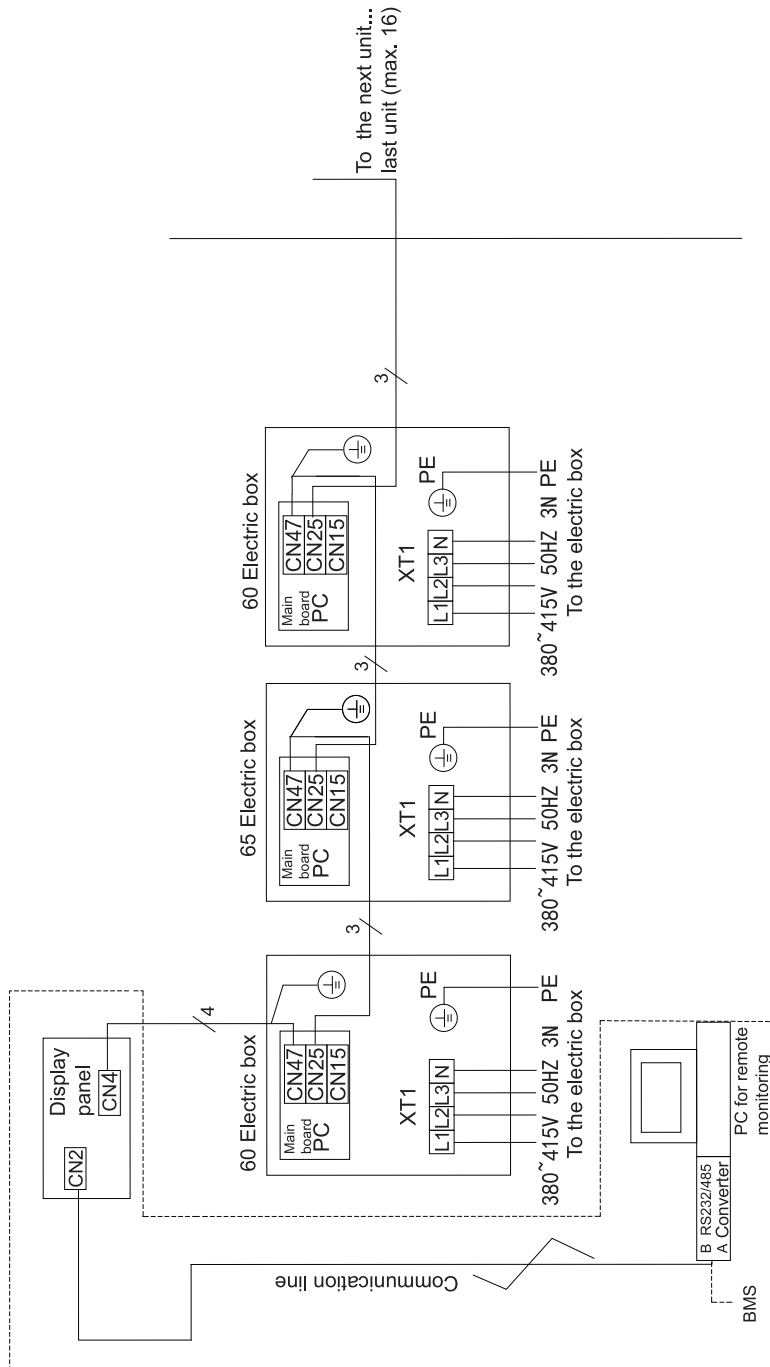

Notes

- (1)CN25 and C47 of each unit should be connected through the three-core grounded communication line with the shielding layer. The ground wire of the communication lien should be grounded reliably as shown in the figure above.

- (2) The CN4 of the display panel should be connected to the unused CN47 at the main board of the unit though the four-core grounded communication with the shielding layer. Pay attention that the grounding wire of the communication line is close to the main board and should be connected to it.
- (3) The power lines should be connected to L1, L2, L3, and N at XT1 through a piece of four-core rubber sleeve cable as shown in the figure above.
- (4) There are two solutions for remote monitoring.
 - 1) Install the remote monitoring software at the PC.
 - 2) Based on CARDIFF provided Modbus protocol, the user can do second development to this protocol.

Note: those enclosed by the dotted lines indicate the remote monitoring equipment. When the quantity of the display panel exceeds 30 or length of the communication line exceeds 800m, extra photoelectric relay is required. The photoelectric relays, communication lines (class 5 twist pairs), converters are optional. PC should be prepared by the user themselves.

- (5) "35" indicates the unit CWCH4IN-35KT. Each unit is taken as a module.
"60" indicates the unit CWCH4IN-60KT. Each unit is taken as a module.
"65" indicates the unit CWCH4IN-65KT. Each unit is taken as a module.
"70" indicates the unit CWCH4IN-70KT. Each unit is taken as a module.

7. 6 Setup of Toggle Switches on the Motherboard

Five-bit toggle switches are used for indicating hardware address (1~16) of modules, with module No. displayed in turn on the panel as Module 1, Module 2,, Module 16. Toggle switches 1,2,3,4 and 5 are binary codes, with 1 for the lowest bit and 5 for the highest bit. Comparison drawings are as follows (Caution: only in the condition of power supply shutoff can toggle switches be set):

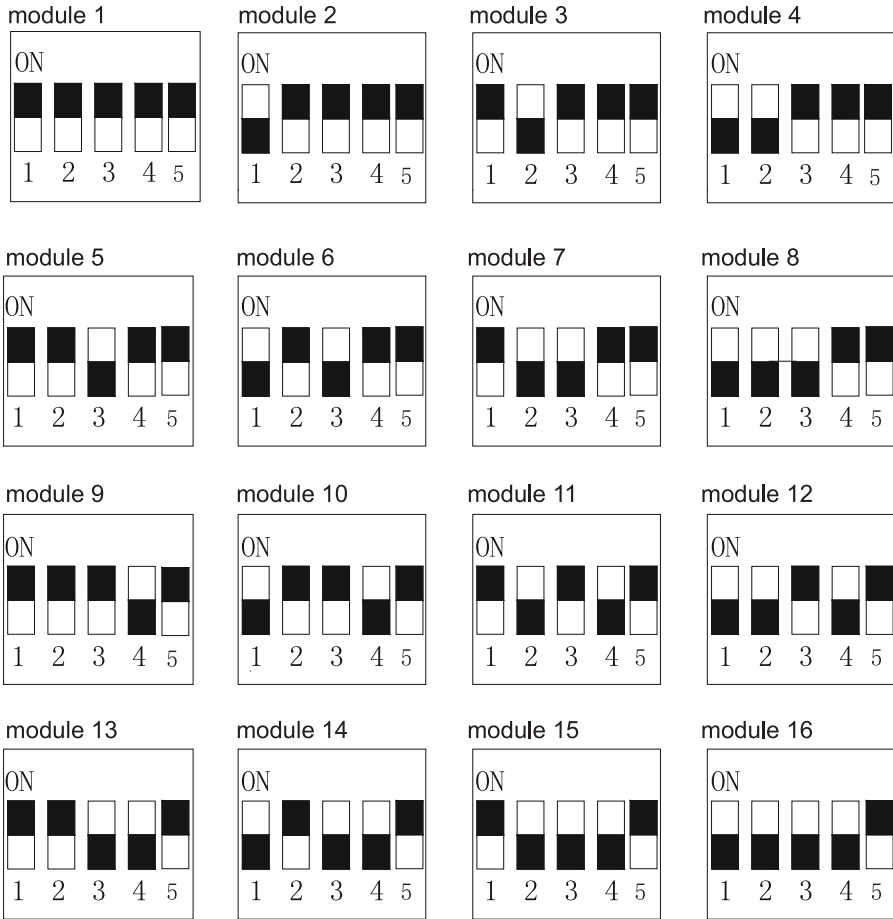





Note: the black block represents where the projecting lever of the toggle switch is.

7.7 Jumpers

When it is required to replace the main board, be sure the main board can match with the applicable jumpers.

Table 7.7.1 Jumpers List

Model	Code	Jumper No	Matched Compressor
CWCH4IN-35KT	4202021905		QXAS-H80zN345H
CWCH4IN-60KT	4202021907		QXAS-H80zN345H
CWCH4IN-65KT	4202021906		QXAS-H80zN345H
CWCH4IN-70KT	4202021908		QXAS-H80zN345H

8 Commissioning and Maintenance

The unit shall be maintained periodically by the skilled servicemen from CARDIFF or a designed person under our professional guide to guarantee the unit operates reliably in a long term. **8. 1 Check before Startup**

Please finish the following steps before starting the system.

- (1) Before energization, be sure the insulation resistance between the wiring terminal and ground complies with the local codes and regulations and check if the motor meets the insulation requirement with a resistance meter.
- (2) Check if all connections are in good condition and clean.
- (3) Close the main power switch.
- (4) Check if the voltage between terminals keeps balance within deviation of 2%.
- (5) Be sure the power cord is capable of carrying the rated current on the nameplate.
- (6) Be sure all valves of water and refrigerant pipeline are placed properly.
- (7) Reset all hand reset control elements.

Be sure all sensor are placed installed properly.

8. 2 Requirements on Water Quality and Cleaning

Be sure to open the water pump after the water system has been flushed times and the water quality has met the requirements and meanwhile be sure the water flow rate and pressure are within the allowable range.

The industrial water generates little scale when used as the refrigeration medium while the well or river water will generate much more scale and sands which would reduce the flow rate of the evaporate and cause freezing. Therefore, the well or river water must be firstly treated with the water softening equipment and analyze the PH, heat conductivity, Cl ion, and S ion before use.

Table 8.2.1 Water Quality

Water Quality Requirement						
Items			Cold/hot water		Trend	
			Circulating water	Makeup water	Corrosion	Scale
Basic items	PH (25°C)	6.8-8.0	6.8-8.0	6.8-8.0	0	
	Electrical conductivity (25°C)	µs/cm	<400	<300	0	0
	Cl ⁻	mg (Cl ⁻) /L	<50	<50	0	
	SO ₄ ²⁻	mg (SO ₄ ²⁻) /L	<50	<50	0	
	Acid consumption (PH4.8)	mg(CaCO ₃)/L	<50	<50		0
	Total hardness	mg(CaCO ₃)/L	<70	<70		0

Total hardness	Fe	mg(Fe)/L	<1.0	<0.3	0	0
	S ²⁻	mg(S ²⁻)/L	Undetectable	Undetectable	0	
	NH ₄ ⁺	mg(NH ₄ ⁺)/L	<1.0	<0.3	0	
	SiO ₂	mg(SiO ₂)/L	<30	<30		0
NOTE: "o" indicates possible corrosion or scaling.						

Even if the water quality is under the strict control, calcium dioxide or other minerals will still form on the surface of the heat exchanger which will affect the heat exchange efficiency and be eliminated by formic acid, lemon acid, acetic acid or other organic acid.

Therefore, the pipe system should be cleaned periodically. Oxalic acid, acetic acid and formic acid can be used as the organic cleaning agent, but the strong chloracid is not allowed as it will corrode the copper tube of the heat exchanger and then lead to water and refrigerant leakage.

■ Preparation of Materials and Tools

Several bags of environmental friendly scale remover, or similar cleaning liquid.

■ Cleaning Instructions

Step 1: estimate the required amount of scale remover in accordance with the system water volume and severity of scaling.

Step 2: add the scale remover to the water tank and the scale remover.

Step 3: start through the contactor the water pump every 10 minutes and spread the scale remover in water more quickly and widely.

Step 4: after that, follow the steps below:

- (1) let the water pump run for another 1-2 hours.
- (2) 1-2 hours later, change the cleaning solution to anti-rusting agent. Then, drain the water system and check the water quality. If water is cloudy, then it indicates the cleaning effect is satisfactory.
- (3) open the water inlet to see if scale on the shell and tube has been removed. If not, clean the shell and tube separately again by the skilled serviceman and then rinse them. If there is still sand, scale and other foreign matters at the bottom of the shell and tube, let cleaning solution in from the inlet pipe and then let the foul water out through the drain outlet.
- (4) fully charge the water system and let it run for another 1-2 hours.
- (5) stop the unit to drain up waste solution. If impossible, drain it with making up water at the same time until all waste solution has been drained out completely (at this time water is transparent and PH is 7).
- (6) repeat 4 and 5.
- (7) clean or change the filters in the water system.
- (8) see if the difference between the entering and leaving water temperature is improved.

■ Precautions

(1) Although the cleaning agent is innocuous, care also should be taken not to let it spill into eyes.

(2) The serviceman with injuries on the hand is not allowed to take this task.

Check the running status before and after cleaning, summarize the cleaning effect and record the running data before and after cleaning.

8. 3 Trial Run

(1) When the unit has not been used for a long period or the ambient temperature is below 5°C, keep the unit energized at least 8 hours before startup to preheat the crankcase of the compressor so as to evaporate the liquid refrigerant inside the compressor which otherwise would cause adverse effect on the compressor.

(2) Be sure valves are opened properly to prevent the compressor from being damaged by the abnormal high pressure.

(3) Check the power supply and insulation conditions, and see initial settings of each control and protection element are satisfactory, and then record relative records.

(4) Turn on the wired controller to check the error record. If any error exists, eliminated it before restarting the unit.

(5) When a single unit has run stably, check the entering and leaving water temperature difference, and adjust the water damper to make the temperature difference reach 2.5~6°C and then record related data.

(6) When all units have run stably, check the entering and leaving water temperature difference of each on, and adjust the water damper to make the temperature difference reach 2.5~6°C and then record related data.

(7) When all loads have been started and all units have run stably for one hour, check the air conditioning and water temperature and see if they can meet the client's requirement and then record related data.

8. 4 Routine Startup/Shutdown

It is recommended to start the system through the wired controller in the sequence of the water pump first and then the main unit, and stop the system in a reverse sequence.

When the unit is not used for a long term or temperature is below 5°C, remember to keep the unit energized at least 8 hours before startup to preheat the crankcase of the compressor so as to evaporate the liquid refrigerant inside the compressor which otherwise would cause adverse effect on the compressor.

When the function of the auxiliary electric heater is activated through the control panel, if the ambient temperature is quite low and out of the nominal heating range, the control panel will tell "As ambient temperature is low, startup is not allowed". At this point, the auxiliary electric heater will work, with the running indicator lighting on, the water pump running but the compressor stopped.

When the function of the auxiliary electric heater is deactivated through the control panel, if the ambient temperature is quite low and out of the nominal heating range, the control panel

will tell “As ambient temperature is low, startup is not allowed”. At this point, the auxiliary electric heater will not work, with the running indicator lighting off and both the water pump and compressor stopped.

△NOTE

When the unit is ready to perform heating but water temperature is below 20°C, in order to keep stable and reliable operation, please do not start the terminal units until water temperature goes up to 35°C.

8. 5 Maintenance to the Main Parts

- (1) During normal operation, the water pump is under the control of the main unit. However, when flushing the water system, do not let the main unit control the water pump.
- (2) Do not start the unit until the water system has drained completely.
- (3) Do not manually restart the unit until the stop interval exceeds 6 minutes.

8. 6 Maintenance during Long-term Downtime

When the chiller is going to be stopped for a long period, maintenance listed below shall be performed:

- (1) Take the leakage test for the refrigerant tube. If leakage occurs, eliminate it.
- (2) Maintain the water pump and air conditioning divides in accordance with the suggestions provided by the manufacturer.
- (3) Drain the water system by opening the discharge valve (especially in winter) to avoid frostbite on the shell and tube.
- (4) Switch off the power supply of the chiller and the water pump.
- (5) Clean and dry the inside and outside surface of the chiller. Then, cover it against dust.

8. 7 Startup after Long-term Shutdown

Preparations shall be taken when starting up the chiller which has not been used for a long period.

- (1) Completely check and clean up the chiller.
- (2) Clean the water piping system.
- (3) Check the water pump.
- (4) Tighten all connectors.
- (5) Take the leakage test for all piping. If leakage occurs, eliminate it.
- (6) Regulate the water flow through the balance valve and check the water pressure.
- (7) Check if the fan rotates properly.
- (8) Check if the system vibration and noise are acceptable.

8. 8 Parts Replacement

Only parts supplied by Gree can be replaced instead of similar parts supplied by others.

8. 9 Refrigerant Charging

Refrigerant charging should be done based on the discharge and suction pressure. An air tight test must be taken on the condition refrigerant leaks or some part is required to be replaced. Refrigerant charging comes into two cases stated below.

◆ Complete charging

In this case, take a leakage test by charging hi-pressure nitrogen (15~20kg) or refrigerant into the system. If soldering is required, note that gas inside the system must be expelled firstly. The whole system must be dried and vacuumed prior to charging.

- (1) Connect the manifold gauge.
- (2) Vacuum the system with the vacuum pump.
- (3) After the system pressure reaches the required value (<80Pa) for more than 30 minutes and keeps below 100Pa, charge refrigerant at the low pressure side as per the rated specification on the nameplate.
- (4) Refrigerant charge will be affected by the ambient temperature. When charged refrigerant is under the required amount, add in accordance with the other charging case stated below.

◆ Adding

Connect the refrigerant charging port at the lower pressure side to the refrigerant tank and install a manifold gage.

- (1) Circuit the chilled water and start up the unit.
- (2) Charge refrigerant vapor into the system slowly and check the suction and discharge pressure.

WARNING

- (1) When performing the leakage and air tight test, never charge oxygen, acetylene and other flammable and toxic gases but only hi-pressure air, nitrogen or refrigerant.
- (2) Mineral scale on the surface of the heat exchanger will affect the heat exchanging efficiency and increase the water resistance and lower the refrigeration capacity. Therefore, it should be cleared away through dilute acid. Note that contents of different water quality vary and should be treated with different type of acid by the qualified chemical company.

8. 10 Removal of the Compressor

Please take the steps below when the compressor is required to be removed.

- (1) Cut off the power supply.
- (2) Recover the refrigerant in a reasonable speed to prevent oil from being drawn out.
- (3) Remove the power cord and the temperature sensor.
- (4) Unsolder the soldering spots of the suction and discharge lines.
- (5) Remove the screw bolts of the compressor and check the oil quality and accumulator.
- (6) Remove the compressor.

(7)Clean up the pipeline.

8. 11 Freeze Protection

When the flow passage of the shell-and-tube heat exchanger is frozen up, it would cause serious damage to the heat exchanger, such as cracking and leakage which are out of warranty, therefore, the user should take measures stated below for freeze protection :

- (1)In order to make sure the unit can automatically perform defrosting under low temperature, the water pump must be interlocked with the unit.
- (2)Under subzero condition, when the unit is required to perform cooling, anti-freeze liquid should be added into the water system based on the table below.
- (3)Under subzero condition, when the unit is not required to perform cooling for a short term, the unit should be powered on; when the unit is not required to perform cooling for quite a long term, disconnect the power supply and then drain the shell and tube completely.

Table 8.11.1 Thermal and Physical Properties of the Glycol Solution

Quality Concentration	Initial Freezing Temperature	Density
16	-7	1020
19.8	-10	1025
23.6	-13	1030
27.4	-15	1035
31.2	-17	1040
35	-21	1045
38.8	-26	1050
42.6	-29	1055
46.4	-33	1060

Notes:

- (1)This table is cited from Design Manual for Practical Refrigeration Engineering published by China Architecture Industry Press. If physical data of the glycol has been provided by the manufacturer, it always prevails.
- (2)Once the glycol is taken as the second refrigerant, its initial freezing temperature of the glycol solution should be 2~3°C lower than the lowest environment temperature.

8. 12 Rountine Maintenance

Routine maintenance shall be performed periodically by the qualified technician so as to extend the service life of the unit and lower the possibility of occurrence of faults.

Record weekly the running status of the unit to facilitate troubleshooting for the servicemen.

■ Daily Maintenance

- (1)Check the circulating water pump and the flow rate.
- (2)Check the voltage and power supply.

■ Weekly Maintenance

(1) Check the main unit, like if the compressor runs with abnormal noise, if the distribution box is attached securely and if the pipeline generates abnormal vibration or leakage.

(2) Record key parameters, like pressure, pressure etc.

■ Quarterly Maintenance

(1) Check the electric wiring and electric insulation.

(2) Check and adjust the set point of the temperature.

■ Yearly Maintenance

(1) Check valves and pipeline of the water system. If necessary, clean the filter and analyze the water quality. If the water circuit needs to be cleaned, please consult the assistance of the qualified personnel.

(2) Clean the corrosive surface and paint it again, and check if the door of the electric control cabinet is tightly closed.

(3) Check if the pipeline is secured and so the water pump and fittings. Additionally, check if the refrigerant charge is sufficient, if not, add some.

(4) Perform the items for weekly maintenance.

(5) Check if the control device is set and acts properly.

(6) Check if the refrigerant pipe is attached securely.

(7) Check if the refrigerant pipe is attached securely.

8. 13 Precautions

(1) Take periodic maintenance to the unit to guarantee normal operation.

(2) Once refrigerant leaks, shut down the unit immediately and contact the serviceman. No open fire is allowed in that refrigerant will decompose into toxic gas.

(3) Switch off the main power supply in case of a fire hazard and extinguish it with effective measures.

(4) The working environment shall be far away from the inflammable substance, such as petroleum and alcoholic etc. to avoid explosion.

(5) The unit is allowed restarted only after any malfunction is eliminated, otherwise refrigerant or chilled water would leak, in which case, it is imperative to turn off all switches or the main power supply.

(6) Do not short-circuit the protection device, otherwise it would cause some malfunction.

9 Troubleshooting and After-sales Service

9.1 Troubleshooting Measures

Error	Possible Causes	Troubleshooting Measures
Shutdown against high pressure protection of the compressor	<ol style="list-style-type: none"> 1. Uncomplete vacuuming. 2. Too high environment temperature. 3. Condenser fins are dirty and there are blockages. 4. Inadequate condensing air flow and the condenser fan failed. 5. Failed high pressure cutoff. 6. Overcharged refrigerant. 	<ol style="list-style-type: none"> 1. Revacuum the system and recharge refrigerant. 2. Improve ventilation. 3. Clean condenser fins. 4. Repair the condenser fan. 5. Check the high pressure switch. 6. Check the refrigerant charge and discharge some refrigerant.
Shutdown against overloading of the compressor motor	<ol style="list-style-type: none"> 1. The voltage is too high or too low. 2. The discharge pressure is too high or too low. 3. The return water temperature is too high. 4. The overloaded element is faulty. 5. The environment temperature is too high. 6. There is phase loss for the compressor. 7. The compressor motor is short-circuited. 	<ol style="list-style-type: none"> 1. Check if the voltage is or no less than 80% and the phase difference does not exceed $\pm 30\%$. 2. Check discharge pressure and find out causes. 3. Check return water temperature and find out causes. 4. Check the compressor current. 5. Improve ventilation. 6. Check the three phase resistances.
Shutdown against low pressure protection of the compressor	<ol style="list-style-type: none"> 1. The electrostatic expansion valve is faulty. 5. The low pressure cutoff is faulty. 3. Refrigerant is insufficient. 4. The entering chilled water temperature is 5. lower than the rated. 6. The chilled water flow is too low. 	<ol style="list-style-type: none"> 1. Replace the coils or even the valve body. 2. Check the low pressure cutoff. 3. Check and charge refrigerant. 4. Check if the chilled water is down-temperature. 5. Adjust the chilled water flow.

<p>Failed startup of the compressor</p>	<ol style="list-style-type: none"> 1. The overcurrent relay tripped off and the fuse was burnt out. 2. The control circuit was open. 3. There is no current. 4. Low/high pressure protection. 5. The contact coils is burnt out. 6. The water flow is open-circuited. 7. The wireless controller raised the alarm signal. ON/OFF time setting by the wireless controll is incorrect. 8. The sensed temperature exceeded the rated. 	<ol style="list-style-type: none"> 1. Replace it. 2. Check wiring of the control system. 3. Check the power supply. 4. See corresponding statement above. 5. Replace it. 6. Check the water system. 7. Check the alarm type and take corresponding corrective measure. 8. Check and reset it.
<p>Temperature sensor protection</p>	<ol style="list-style-type: none"> 1. The buld plug and the main board plug were connected incorrectly. 2. The temperature bulb was damaged. 3. The main board was damaged. 	<ol style="list-style-type: none"> 1. Check if the bulb plug was connected to the correct main board plug. 2. Replae it. 3. Replace it.
<p>Pressure transducer error</p>	<ol style="list-style-type: none"> 1. The pressure sensor is open-circuited. 2. The pressure sensor is short-circuited. 3. The pressure sensor is damaged. 	<ol style="list-style-type: none"> 1. Check the circuit of the pressrue sensor. 2. Replace it.
<p>Flow switch protection</p>	<ol style="list-style-type: none"> 1. The water pump has not started. 2. The water flow is too low. 3. The water flow switch was damaged. 4. There was air inside the waer system. 	<ol style="list-style-type: none"> 1. Start the water pump. 2. Adjust the water flow. 3. Adjust the water flow. 4. Dispel air inside the water system.

<p>Protection against the failed 4-way valve</p>	<p>1. The entering and leaving water temperature sensor fell off or installed incorrectly. 2. The 4-way valve was damaged.</p>	<p>1. Check if the entering and leaving water temperature sensors were installed correctly and if silica gel at the probe for heat conduction was applied properly. 2. Replace it.</p>
<p>Protection against the failed compressor IPM module</p>	<p>1. The voltage suddenly dropped. 2. The compressor drive board was damaged.</p>	<p>1. Check if it occurred before protection. 2. Replace it.</p>
<p>Failed discharge temperature sensor</p>	<p>1. Too low water temperature. 2. The discharge temperature sensor fell off.</p>	<p>1. Decrease the load to improve the water temperature. 2. Check if the discharge temperature sensor installed correctly.</p>

9. 2 After-sales Service

When the unit in warranty has a quality issue or fails to operate properly under the allowable operation condition, please contact the local sales representative for free service.

The user is required to designate personnel to take charge of the unit following the instructions covered in this manual, otherwise any maintenance cost caused by the improper operation will be at the user's expense.

Appendix A: Inspection Records Prior to Commissioning

Installation	Routine Check										
Chilled water pipeline	Location		Min. distance from barriers			>2m (Ref.)					
	Foundation(Concrete/Steel frame)		Shock absorber			>3m (Ref.)					
Load	Arrangement		Highest point and lowest point			Air release valve (On/Off)					
	Water pump flow	Shutoff valve (On/Off)		Drain valve (On/Off)		Filter (On/Off)		Flushing times			Water quality
		Inlet	Outlet								
	Pressure gauge	Thermometer		Flow switch state		Insulation state		Shutoff valve state			
Inlet		Outlet									
FCU	Air supply outlet		Air discharge state		Air conditioning space insulation state		Refrigeration load state				
	Supply voltage (V)		Allowable range 380~415V		Voltage fluctuation		%		Allowable value <5%		
Power supply	Interphase insulation resistance MΩ		Phase-ground insulation resistance MΩ								
	Rab	Rbc	Rac	Min. allowable value	Rag	Rbg	Rcg	Min. allowable value			
	1MΩ		1MΩ			1MΩ					
Insulation of the whole unit (main air switch)	Interphase insulation resistance MΩ		Phase-ground insulation resistance MΩ								
	R12	R23	R13	Min. allowable value	R1g	R2g	R3g	Min. allowable value			
	1MΩ		1MΩ			1MΩ					
Insulation of the compressor (terminal block)	Interphase insulation resistance MΩ		Phase-ground insulation resistance MΩ								
	R12	R23	R13	Min. allowable value	R1g	R2g	R3g	Min. allowable value			
	1		1			1					
Refrigeration system	Repair brazing	Vacuuming (MPa)		Max. allowable value		0.0080MPa		Duration (min)		>30min	
	System I balance pressure(Mpa)		System II balance pressure (MPa)		Ambient temp (°C)						
	Power supply monitor (3Ph)		Leaving water temp (°C)		Vacuuming stop time						
Control and protection devices	Setpoint	Deviation		Setpoint							
	380~415V		5s								

Appendix B: Trial Run and Commissioning Records

Pre-start		Water system		Direction		Water temp		Sufficient air discharge (Y/N)	
		Flow rate (T/h)		90% flow rate		Full load (Y/N)		Ambient temp (°C)	
Startup		Start current (A)		Startup state (Normal/Abnormal)		Chilled water (°C)		Entering Leaving	
10min after startup		Hi-pressure		Low-pressure		Entering air temp.		Entering Leaving	
30min after startup		Hi-pressure		Low-pressure		Chilled water (°C)		Entering Leaving	
Running state		System I		System II		Entering air temp.		Entering Leaving	
Troubleshooting		System I		System II		Chilled water (°C)		Entering Leaving	
Flow control		Final flow rate (T/h)		Entering water temp (°C)		Nominal value: 12/7 °C			
Unloading state		System I leaving water temp at shutdown (°C)		1st downtime (min)		Leaving water temp at 2nd startup (°C)		2nd downtime (s)	
Unloading state		System II leaving water temp at shutdown (°C)		Runtime (s)		Vacuuming time (s)		5s	
Unloading state		System I leaving water temp at shutdown (°C)		1st downtime (min)		Leaving water temp at 2nd startup (°C)		2nd downtime (s)	
Unloading state		System II leaving water temp at shutdown (°C)		Runtime (s)		Vacuuming time (s)		5s	
Operation training		Precautions		Emergency stop		Special service			
Delivery		Precautions		Emergency stop		Special service			
Conclusion		Precautions		Emergency stop		Special service			

Cardiff[®]
 **ecoenergy**



600005061255